



City of Hayward Recycled Water Use Guidelines

October 2020

Table of Contents

Section 1. Introduction	2
1.1. Purpose.....	2
1.2. Background.....	2
1.3. Local Authority	2
1.4. Severability.....	3
1.5. References.....	3
1.6. City Contacts.....	3
1.7. Acknowledgements.....	3
Section 2. Planning for Recycled Water Use	4
2.1. Acceptable Use	4
Table 1: Recycled Water Use	4
2.2. City Recycled Water Code	6
2.3. Permitting Processes For Recycled Water Customers	7
Figure 1: Permitting Process.....	8
2.4. Protection of Public Health.....	9
Section 3. Design, Installation, and Inspection Requirements	10
3.1. On-Site Design Requirements	10
Table 2: On-site Recycled Water System Design Requirements.....	10
3.2. Information Required on Plans for Irrigation Uses	13
3.3. Use of Recycled Water for Approved Indoor Uses	15
3.4. Inspections and Testing	16
Section 4. Operating and Maintaining Your On-Site Recycled Water System.....	19
4.1. Site Supervisor Responsibilities.....	19
4.2. Customer Responsibilities.....	20
4.3. Cross-Connection Control Program.....	21
4.4. Emergency Procedures.....	23

Appendices

- Appendix A – Definitions and Abbreviations
- Appendix B – City of Hayward Municipal Code for Recycled Water Use
- Appendix C – Recycled Water Service Area Map
- Appendix D – Usage Application and Permit (Sample)
- Appendix E – Standard Details
- Appendix F – Quarterly Self-Monitoring Monitoring Report
- Appendix G – Coverage Test Form
- Appendix H – Recycled Water Do’s and Don’ts

Section 1. Introduction

This section includes information about the purpose, background, and governing regulations for the Recycled Water Use Guidelines.

1.1. Purpose

The purpose of the City of Hayward's (City) Recycled Water Use Guidelines is to instruct the Customer on the process of obtaining recycled water service from the City and to ensure the safe and efficient use of recycled water. This document shall define the requirements for the Customer to design, obtain permits for, construct, operate, and maintain their on-site recycled water system in accordance with the California State Water Resources Control Board (State Water Board) Division of Drinking Water (DDW) criteria.

1.2. Background

These Recycled Water Use Guidelines were developed to be consistent with the requirements promulgated by the State Water Resources Control Board (SWRCB) Order WQ 2016-0068-DDW, Title 22 of the California Code of Regulations, the City's Municipal Code, as well as other codes, laws, statutes, or regulations governing recycled water use. These Recycled Water Use Guidelines have been developed to be consistent with current codes, laws, statutes, regulations, and orders, but these requirements can change without prior approval or knowledge of the City. Customers wishing to utilize these Recycled Water Use Guidelines should consult with the City for any updates to these Recycled Water Use Guidelines which may affect allowable uses of recycled water, design, construction, operations, or maintenance requirements.

To aid in understanding the terminology in this document, a list of definitions and abbreviations is provided in **Appendix A**.

Interested parties may contact the City for copies of documents referenced in the Recycled Water Use Guidelines.

1.3. Local Authority

Recycled water will be distributed to users through a distribution system owned and operated by the City. The City is the local authority that has the responsibility for implementation and enforcement of these Recycled Water Use Guidelines for the use of recycled water in the City of Hayward. Various regulations governing recycled water use are outlined in the City's Municipal Code ordinances that are cited in these Recycled Water Use Guidelines.

1.4. Severability

If any section, subsection, clause or phrase of these Recycled Water Use Guidelines is for any reason held to be invalid, the remaining portions of these Recycled Water Use Guidelines shall remain in effect.

1.5. References

- Limits and regulations set forth in the RWQCB Order 94-072
- California Health and Safety Codes (Division 104, Part 12, Chapters 4 and 5)
- California Water Code (Division 7, Chapters 2, 6, 7, 7.5 and 22)
- Title 22 California Code of Regulations (Title 22)
- Title 17 California Code of Regulations (Division 1, Chapter 5, Group 4)
- Title 26 California Code of Regulations (Div. 22, Sampling & Analysis Sections)
- City of Hayward Recycled Water Use Ordinance (Chapter 11, Article 6 of the Hayward Municipal Code) see **Appendix B**.
- California State Water Resources Control Board Order WQ 2016-0068 DDW

1.6. City Contacts

For questions about connecting your property to the City's recycled water system, Customers should contact:

Recycled Water Program
City of Hayward
Department of Utilities and Environmental Services
777 B Street
Hayward, CA 94541-5007

Cheryl Munoz
Phone: 510-583-4700
Recycled.Water@Hayward-ca.gov

1.7. Acknowledgements

In preparing this document, the City acknowledges the assistance of a number of entities including the City of Mountain View and the City of San Jose. The City is also grateful to the City of San Jose, South Bay Water Recycling, and the WaterReuse Association for sharing key reference material used to generate these Recycled Water Use Guidelines.

Section 2. Planning for Recycled Water Use

2.1. Acceptable Use

Customers may be able to use recycled water for a variety of applications approved by the Division of Drinking Water (DDW) and per California Code of Regulations Title 22. Each use of recycled water must be approved and permitted by the City in advance. See **Table 1** for a list of acceptable uses. The City of Hayward Recycled Water Program treatment level shall meet or exceed the standards for Disinfected Tertiary Recycled Water which is the highest level of treatment, and has the greatest number of allowable uses.

Table 1: Recycled Water Use

Recycled Water Use	Treatment Level			
	Disinfected Tertiary Recycled Water	Disinfected Secondary 2.2 Recycled Water	Disinfected Secondary 23 Recycled Water	Undisinfected Secondary Recycled Water
Irrigation for:				
Food crops where recycled water contacts the edible portion of the crop, including all root crops	ALLOWED	NOT ALLOWED	NOT ALLOWED	NOT ALLOWED
Parks and playgrounds	ALLOWED	NOT ALLOWED	NOT ALLOWED	NOT ALLOWED
School grounds				
Residential landscaping				
Unrestricted-access golf courses				
Any other irrigation uses not specifically prohibited by other provisions of the <i>California Code of Regulations</i>				
Food crops, surface-irrigated, above-ground edible portion, not contacted by recycled water	ALLOWED	NOT ALLOWED	NOT ALLOWED	NOT ALLOWED
Cemetaries	ALLOWED			
Freeway landscaping	ALLOWED	ALLOWED	NOT ALLOWED	NOT ALLOWED
Restricted-access golf courses				
Ornamental nursery stock and sod farms with unrestricted public access				
Pasture for milk animals for human consumption				
Nonedible vegetation with access control to prevent use as a park, playground or school grounds				
Orchards with no contact between edible portion and recycled water	ALLOWED	ALLOWED	ALLOWED	ALLOWED
Vineyards with no contact between edible portion and recycled water				
Non food-bearing trees, including Christmas trees not irrigated less than 14 days before harvest				
Fodder and fiber crops and pasture for animals not producing milk for human consumption				
Seed crops not eaten by humans				
Food crops undergoing commercial pathogen-destroying processing before consumption by humans				
Ornamental nursery stock, sod farms not irrigated less than 14 days before harvest				

Recycled Water Use	Treatment Level			
	Disinfected Tertiary Recycled Water	Disinfected Secondary 2.2 Recycled Water	Disinfected Secondary 2.3 Recycled Water	Undisinfected Secondary Recycled Water
Supply for impoundment:				
Nonrestricted recreational impoundments, with supplemental monitoring for pathogenic organisms	ALLOWED ²	NOT ALLOWED	NOT ALLOWED	NOT ALLOWED
Restricted recreational impoundments and publicly accessible fish hatcheries	ALLOWED	ALLOWED		
Landscape impoundments without decorative fountains			ALLOWED	
Supply for cooling or air conditioning:				
Industrial or commercial cooling or air conditioning involving cooling tower, evaporative condenser, or spraying that creates a mist	ALLOWED ³	NOT ALLOWED	NOT ALLOWED	NOT ALLOWED
Industrial or commercial cooling or air conditioning not involving cooling tower, evaporative condenser, or spraying that creates a mist	ALLOWED	ALLOWED	ALLOWED	
Other Uses:				
Groundwater Recharge	ALLOWED under special case-by-case permits by the RWQCB ⁴			
Flushing toilets and urinals	ALLOWED	NOT ALLOWED	NOT ALLOWED	NOT ALLOWED
Priming drain traps				
Industrial process water that may contact workers				
Structural fire fighting				
Decorative fountains				
Commercial laundries				
Consolidation of backfill material around potable water pipelines				
Artificial snow making for commercial outdoor use				
Commercial car washes, not heating the water, excluding the general public from the washing process				
Industrial process water that will not come into contact with workers		ALLOWED	ALLOWED	
Industrial boiler feed				
Nonstructural fire fighting				
Backfill consolidation around nonpotable piping				
Soil compaction				
Mixing concrete				
Dust control on roads and streets				
Cleaning roads, sidewalks and outdoor work areas				
Flushing sanitary sewers				ALLOWED

This summary is prepared by WaterReuse Association of California, from the December 2, 2000 Title 22 adopted Water Recycling Criteria, and supersedes all earlier versions.

If a Customer wishes to use and receive recycled water for any uses not defined in Table 1, the Customer should contact the City to discuss their proposed use of recycled water.

Service Requirements

The use of recycled water shall be in accordance with federal, state and local regulations. In the event where there is a conflicting or inconsistent rule or regulation, the more stringent criteria shall apply.

Service to recycled water customers may be terminated or interrupted due to the following:

- Quality of the recycled water does not comply with the requirements of Title 22 recycled water quality for the specified use.
- Customers' use of the recycled water does not conform to the permitted use.

The City will be delivering a recycled water quality to its customers that meets or exceeds the requirements set for a disinfected tertiary recycled water. In the event that new recycled water criteria are issued by the State Water Board, RWQCB, or DDW, the City will adhere to the new standards and provide the necessary documentation or technical reports to ensure compliance.

2.2. City Recycled Water Code

The City adopted a Recycled Water Use Ordinance (Chapter 11, Article 6 of the Hayward Municipal Code) in December 2015 which governs the use and conditions of recycled water. The article of the City Code related to recycled water use is presented in **Appendix B** and addresses the following topics:

- Section 11-6.1 Findings
- Section 11-6.2 Recycled Water Policy
- Section 11-6.3 Definitions
- Section 11-6.4 Recycled Water Service Areas
- Section 11-6.5 Mandatory Recycled Water Use by Existing Water Users
- Section 11-6.6 Recycled Water Use by New Developments

A map of the City's current Recycled Water Service Area is included as **Appendix C**.

2.3. Permitting Processes For Recycled Water Customers

The Customer must obtain a Recycled Water Use Permit from the City in order to begin recycled water service. See **Appendix D** for a Sample Recycled Water Use Permit. The Customer shall also designate a Recycled Water Site Supervisor and share their contact information with the City. See **Section 4.1** for the responsibilities of the Recycled Water Site Supervisor.

To initiate the process, the City may contact potential customers regarding recycled water service, or interested parties may reach out to the City. Once the City and Customer agree that recycled water is viable for use at the customer's site, the general process for connection of the site to the City's recycled water system is shown on **Figure 1** and described as follows:

1. Customer obtains recycled water submittal package requirements from City. A complete submittal package includes a Water Service Application, Recycled Water Service Permit Application (**Appendix D**), Recycled Water Plans, and Customer Site Agreement.
2. Customer works with City to coordinate location for recycled water service.
3. Customer prepares documents and submits recycled water submittal package to City. Customer is encouraged to consult with **Section 3** and **Appendix E** of these Use Guidelines, which describe the necessary elements to be included in the plans prepared by the Customer.
4. City obtains approval from State Division of Drinking Water approval for the recycled water submittal package.
5. Customer performs recycled water construction in accordance with the DDW approved package. City performs construction inspection (backflow devices, recycled & potable meters, pipe class, color, marking, depth, indoor plumbing requirements, and signs).
6. An AWWA certified cross connection control specialist performs the cross-connection test prior to connection of customer's irrigation system to recycled water. The cross-connection test procedure is further documented in **Section 4.3**.
7. City sets recycled water meter, disconnects site from potable water, and removes potable water meter.
8. City and Customer perform coverage test after the customer connects their irrigation system to the recycled water meter.
9. Customer submits final recycled water service permit documents (including record drawings and proof of Site Supervisor training).
10. City issues final Recycled Water Use Permit.
11. Customer submits quarterly self-inspection report forms to City.

For sites where recycled water is to be used in the building interior or for a single residence's outdoor landscape irrigation, a Dual-plumbed Facility Report must be completed by the Customer and Submitted to the City. See **Section 3.3** for submittal requirements for Dual-Plumbed Facility Report.

Figure 1: Permitting Process

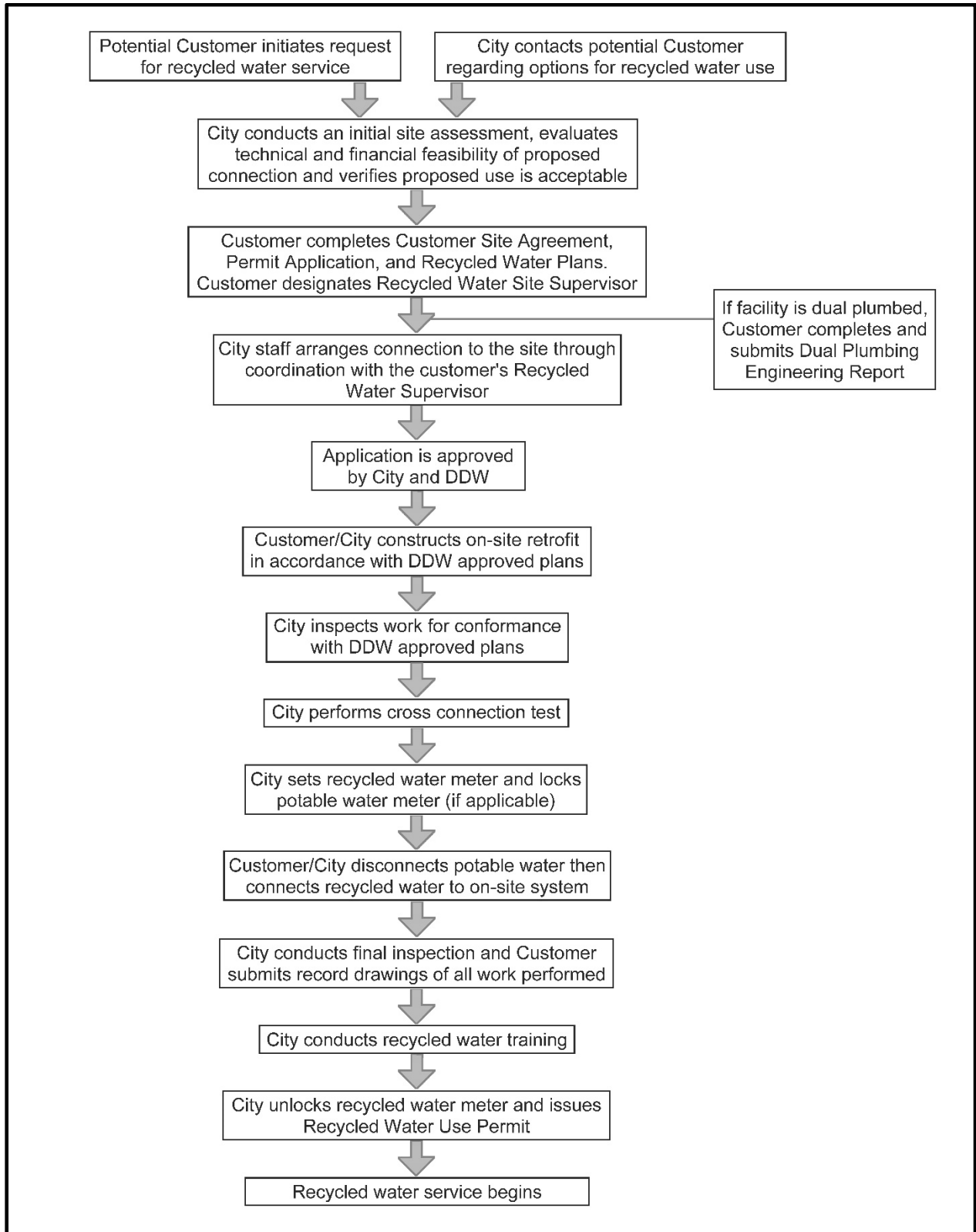

2.4. Protection of Public Health

The City reserves the right to take any appropriate action necessary, with respect to the operation of the Customer's on-site recycled water system, to safeguard the public health. If real or potential hazards are evidenced any time during construction or operation of the on-site recycled water system, the City reserves the right and has the authority to terminate recycled water service immediately, without notice. These hazards include, but are not limited to:

- Cross-connections with the potable system
- Unapproved/prohibited uses of recycled water
- Improper tagging, signing or marking

If the on-site recycled water system is found to be in violation of the Recycled Water Use Permit conditions, the City will direct the Customer to mitigate these violations. A site inspection will be scheduled after a reasonable period to ensure compliance.

The City may elect to temporarily replace the recycled water supply with potable water. All modifications required to replace the recycled water supply with potable water, including the installation of a new lateral connecting to the potable water pipeline, installation of a backflow preventer, new connection to the on-site water pipeline, and disinfection of the Customer's on-site water supply in accordance with the City Municipal Code will be at the Customer's expense. Failure to comply with the terms of the Recycled Water Use Permit may result in termination of recycled water service.

Section 3. Design, Installation, and Inspection Requirements

The purpose of this section is to provide designers of on-site recycled water system with rules and guidelines for design, installation, and inspection.

Facilities referred to herein as “on-site” include all piping and appurtenances located on the Customer’s property downstream of the potable or recycled water meter. All on-site facilities are owned, operated, and maintained by the Customer. The following design and identification requirements apply to on-site facilities connected to the City’s recycled water system.

All recycled water facilities upstream of, and including, the recycled water meter and meter box are the property and responsibility of the City. These facilities include all recycled water distribution pipelines, the recycled water lateral, meter box, and meter. The design requirements for the on-site facilities begin at the downstream end of the recycled water meter.

3.1. On-Site Design Requirements

Table 2 outlines the general and specific on-site design requirements for the use of recycled water. For other uses of recycled water, site-specific design questions, or to discuss the requirements for your proposed project, Customers should contact the City at the contact information shown in **Section 1.6**.

Before any new on-site recycled water system is constructed or any existing on-site recycled water system is modified, **on-site recycled water system plans must be prepared by the Customer and approved by the City.** Please refer to **Section 2.3** for the process to get the plans approved, and **Section 3.2** for the information required to be included on these plans. Approval of these plans will be contingent upon evidence that the Customer’s proposed use of recycled water and proposed design of the on-site recycled water system complies with these Recycled Water Use Guidelines.

Table 2: On-site Recycled Water System Design Requirements

No Cross-Connections	No cross-connections are allowed between the on-site recycled water system and any other water system.
Pressure	The City’s recycled water system provides recycled water at a minimum delivery pressure of 80 psi. Designers should contact the City to determine the pressure available at their recycled water point of connection. Customers are required to install a pressure regulating valve for their on-site recycled water system.
Service Connection	Designers must contact the City or consult their approved development plans to verify the recycled water meter location, the size of the lateral, and meter size approved to serve their facility. All new recycled water services shall be located at least 4 feet from any potable water service.

<p>Backflow Prevention on Recycled Water Connections</p>	<p>Backflow preventers are required for all potable water services on sites where recycled water is used.</p> <p>Backflow preventers are generally not required on recycled water services for irrigation purposes. However, the City retains the sole discretion to require the Customer to install a backflow preventer on any recycled water connection.</p> <p>Recycled water backflow preventers shall be the type specified in the City Municipal Code, shall be tested and monitored through the City's backflow device testing program, and shall be labeled and painted in accordance with these Recycled Water Use Guidelines.</p> <p>New backflow preventers installed by the Customer for their on-site recycled water system must meet the requirements outlined in the Standard Notes and Details contained in Appendix E.</p>
<p>Backflow Prevention on Potable Water Connections</p>	<p>At premises where both recycled water and potable water are present in separate piping systems with no interconnection, a reduced pressure principal backflow device must be located as close as practicable to the downstream side of every potable water meter.</p> <p>All backflow preventers installed by the Customer for sites with an on-site recycled water system must meet the requirements outlined in the Standard Notes and Details contained in Appendix E</p>
<p>Pipe Color and Marking</p>	<p>In general, new irrigation pipe that is installed must be purple and state "Caution - Recycled Water" printed on opposite sides of the pipe with the wording facing upwards. Warning tape with a minimum text width of 3-inches shall run continuously on top of the piping and shall be attached to the pipeline with plastic tape banded around the warning tap and the pipe every five feet on center.</p> <p>In general, existing irrigation pipe that will not be modified as part of the retrofit can remain without change to the pipe color or marking, provided that the pipe conveys water in a manner that allows the site to pass a coverage test, and provided that the pipe is not normally visible.</p> <p>In addition, any existing potable water or recycled water piping uncovered for any reason during construction must be marked according to Appendix E.</p>
<p>Depth of Cover and Pipe Class For All New Pipelines</p>	<p>New pipelines installed by the Customer for their on-site recycled water system must meet the requirements outlined in the Standard Notes and Details contained in Appendix E.</p>

<p>Separation Requirements</p>	<p>New pipelines installed by the Customer for their on-site recycled water system must meet the requirements outlined in the Standard Notes and Details contained in Appendix E.</p> <p>Facilities where the existing buried piping system is converted from potable to recycled water, and where the facilities are not being modified by the proposed conversion from potable to recycled water, do not have to provide the minimum separation requirements for parallel potable and recycled water pipelines. Other separation requirements (e.g. groundwater wells) must be maintained by the existing irrigation systems.</p> <p>Any new buried piping added to the existing piping at these facilities must meet the separation requirements outlined in these Recycled Water Use Guidelines.</p>
<p>Exceptions for Existing Irrigation Systems</p>	<p>Facilities where the existing buried piping system is converted from potable to recycled water, and where the facilities are not being modified by the proposed conversion from potable to recycled water, do not have to provide the minimum separation requirements for parallel potable and recycled water pipelines. Other separation requirements (e.g. groundwater wells) must be maintained by the existing irrigation systems.</p> <p>Any new buried piping added to the existing piping at these facilities must meet the separation requirements outlined in these Recycled Water Use Guidelines.</p> <p>In addition, any existing potable water or recycled water piping uncovered for any reason during construction must be marked according to Appendix E.</p>
<p>Prevent Overspray, Runoff, and Ponding</p>	<p>Irrigation systems must be designed and operated to prevent overspray or runoff of recycled water outside of the approved use area. Ponding of recycled water within the approved use area is prohibited under all conditions.</p>
<p>Protection of Groundwater Wells</p>	<p>Irrigation systems must be designed to prevent irrigation of recycled water within 50 feet of any domestic water supply well. In addition, recycled water impoundments must be located at least 100 feet away from any domestic water supply well.</p>
<p>Protection of Drinking Fountains and Outdoor Eating Areas</p>	<p>Drinking fountains, outdoor eating areas, and other similar areas where food is produced or consumed that are located within the approved recycled water use area must be protected from overspray with recycled water. Protection may be achieved by relocating the irrigation system, directing the spray from the irrigation system to not hit these areas, relocating or modifying the drinking fountains or outdoor eating areas, or other methods approved by the City.</p>
<p>Hose Bibs</p>	<p>Hose bibs are not allowed on the on-site recycled water system. Quick-coupling valves specifically designed for recycled water use that use reverse threaded quick coupler keys shall be used in lieu of hose bibs.</p>
<p>Tagging and Labeling</p>	<p>Please refer to Appendix E for specific tagging and labeling requirements.</p>

<p>Signage</p>	<p>Included in the standard notes are the standard recycled water advisory signs to be located within each Customer’s approved recycled water use area. Recycled water advisory signs are to be placed at locations on the Customer’s property at locations specified by the City. For sites receiving recycled water for landscape irrigation, these signs are located at property entrances (vehicular and pedestrian), water features supplied with recycled water, and at each end of streetscapes or medians.</p> <p>For streetscapes, signs shall be placed no further than 1,000 feet apart from each other.</p> <p>For sites receiving recycled water for toilet and urinal flushing, recycled water advisory signs must be placed in each bathroom using recycled water.</p> <p>The Customer is encouraged to consult with the City to specify exact sign placement. Please refer to Appendix E for specific signage requirements.</p>
<p>Chemical Injection</p>	<p>Delivery of chemical fertilizers or pesticides to landscaped areas by means of injection into the on-site recycled water system is prohibited by the City, unless a City-approved backflow prevention device is installed on the recycled water line.</p>

3.2. Information Required on Plans for Irrigation Uses

The information required to be submitted by the Customer for their on-site recycled water system for landscape irrigation is generally outlined below. Additional information is required for Customers intending to use recycled water for uses within an existing structure that is also plumbed with potable water or landscape irrigation at individual residences.

Preparation of on-site recycled water system plans in accordance with these Recycled Water Use Guidelines does not exempt the Customer from submitting other plans normally required by the City. Other improvement plans must still be submitted in accordance with standard procedures. The Customer may also be required to provide additional information on the plans to confirm that the proposed use of recycled water complies with the requirements of these Recycled Water Use Guidelines.

The on-site recycled water system plans prepared by the Customer for landscape irrigation uses must include, but not be limited to, the following:

Site Plans: Customer shall prepare site plans for their on-site recycled water system. These site plans may encompass multiple sheets, as the designer sees fit. The content of these site plans must include the following items and be stamped by either a civil engineer or landscape architect licensed to perform work in the State of California.

- Boundaries of the intended recycled water use area
- Adjacent streets
- Locations of all major improvements on the site
- All sources of water, including any on-site wells
- Water meters (recycled water and potable water)

- Type and location of backflow prevention devices
- Complete plans for on-site recycled water system including locating strainers, master valves, pressure regulating valves, hose bibs, control valves, irrigation main lines, and quick couplers
- Irrigation system legend that specifies all materials for construction of the on-site recycled water system, including pipelines, appurtenances, and type of water conveyed in that facility
- The Standard Notes and Details included in these Recycled Water Use Guidelines (**Appendix E**) shall be part of the Customer's design drawings submitted for approval to the City, and referenced in the Customer's site plan drawings where applicable (see below)
- Replacement of existing hose bibs or quick couplers on the on-site recycled water system with quick couplers specific to recycled water use (i.e. reverse threaded with purple lid)
- Location of all irrigation system controllers
- Location of recycled water advisory signs
- Location of all new potable water and new recycled water pipelines, and how these pipelines comply with the minimum pipeline separation requirements
- Location of existing potable water pipelines in recycled water use area (if available)
- Clear delineation of what facilities are existing, and what facilities are proposed to be constructed as part of the retrofit
- Location (and callouts for labeling per Standard Notes and Details) of any potable water outlets within the Customer's recycled water use area (e.g. drinking fountains, hose bibs)
- Location of any water impoundments within 100 feet of the Customer's property, including lakes, ponds, reservoirs, and decorative fountains
- Completed Site Information Box (see **Page 15**)
- Other details as required to properly construct the on-site recycled water system
- All public facilities supplied with recycled or potable water service. Public facilities include, but are not limited to: rest rooms, outdoor eating areas, snack bars, swimming pools, decorative fountains, and outdoor showers. The Site Plan shall include the location and type of pipeline supplying these public facilities. If there are no public facilities located in the defined use area, Customer shall note on the plans that no public facilities exist

Standard Notes and Details: The Standard Notes and Details (**Appendix E**), among other things, specify the tagging, labeling, and pipe identification criteria for on-site recycled water systems. The Customer shall tag and label their on-site recycled water system in accordance with these Standard Notes and Details prior to receiving a final recycled water permit from the City.

Site information box: The following information box below must be shown for each separately metered on-site recycled water system. Place this information on the same sheet once on the site plan for each recycled water service.

GENERAL SITE INFORMATION FOR RECYCLED WATER USE

1. LANDSCAPED RECYCLED WATER IRRIGATION USE AREA: (square footage).
2. PUBLIC ACCESS TO SITE GROUNDS IS: (indicate UNRESTRICTED or RESTRICTED).
3. OWNER: (legal property owner's name).
4. PROPERTY MANAGER CONTACT: (name, title and telephone number).
5. TENANT(S): (name(s) and telephone number(s); if not applicable, state NOT APPLICABLE).
6. ON-SITE WELL LOCATIONS: (for example, ONE; if none, state NONE).
7. WELLS ON ADJACENT SITES LOCATED WITHIN 50' OF RECYCLED WATER APPROVED USE AREA OR WITHIN 100' OF ANY RECYCLED WATER IMPOUNDMENT: (for example, ONE; if none, state NONE).
8. OUTDOOR DRINKING FOUNTAINS IN/NEAR THE RECYCLED WATER APPROVED USE AREA: (for example, ONE; if none, state NONE).
9. OUTDOOR EATING AREA(S) IN/NEAR THE RECYCLED WATER APPROVED USE AREA: (for example, ONE; if none, state NONE).
10. WATER FEATURES ON-SITE: (examples below; if none, state NONE).

<u>Number</u>	<u>Type</u>	<u>Water Source</u>
One	fountain	recycled
One	pond	potable

Separate information besides the information in this site information box will be required for design plans where recycled water is desired by the Customer to be used for non-irrigation purposes. This information is summarized in **Section 3.3**.

3.3. Use of Recycled Water for Approved Indoor Uses

If your site is proposing to use recycled water for approved uses within an existing structure that is also plumbed with potable water or landscape irrigation at individual residences, the Customer will be required to prepare a Dual Plumbing Engineering Report for the use of recycled water at that facility. The contents of the Dual Plumbing Engineering Report are defined in the California Code of Regulations, Title 22 Section 60313 and 60314 and California Water Code Section 13522.5.

The following information must be submitted to the City for review and approval prior to operation of a dual-plumbed system:

A detailed description of the intended use area identifying the following:

- The number, location and type of facilities within the use area proposing to use dual plumbed systems
- The average number of persons estimated to be served by each facility on a daily basis
- The specific boundaries of the proposed use area including a map showing the location of each facility to be served
- The person or persons responsible for operation of the dual plumbed system at each facility
- The specific use to be made of the recycled water at each facility

Plans and specifications describing the following:

- Proposed piping system to be used
- Pipe locations of both the recycled and potable systems
- Type and location of the outlets and plumbing fixtures that will be accessible to the public
- The methods and devices to be used to prevent backflow of recycled water into the public system

If an on-site backup system is proposed for the site, details about the on-site backup system and how the City Hayward's potable water system will be protected must be included in the Dual Plumbing Engineering Report.

3.4. Inspections and Testing

Once the plans are approved, and the Customer has obtained all required City permits, the Customer can begin construction of their recycled water system. Though every construction process is unique, the key elements of City involvement in the connection of the Customer's property are as follows:

- Construction inspection
- Cross-connection testing
- Coverage testing
- Final inspection
- Record drawings

How the City is involved in each of these steps is outlined below.

Construction inspection: The City may conduct on-site inspections during the Customer's construction phase to ensure that materials, installation and procedures are in accordance with the approved plans, specifications, and applicable regulations. During the construction of the Customer's on-site recycled water system, City inspection is required to confirm pipeline separation, backflow protection, and other design elements associated with the approval of the conditions included in the approved plans for the Customer on-site recycled water system. The Customer is required to provide the City with 48 hours' notice of the need to inspect, and to not cover up any trenches until the City has had the opportunity to inspect.

Cross-connection testing: In order to prevent cross-connections, the Customer's proposed on-site recycled water system is not allowed to receive recycled water until its site has passed a required cross-connection test. This test is required to ensure the absolute separation of the on-site water supplies (potable, recycled, other).

For new sites, the on-site recycled water system must be supplied with a temporary supply of water to perform a cross-connection test. To provide the on-site recycled water system with water during the cross-connection test, a jumper (temporary connection) to an on-site potable water system is constructed by either the City or the Customer. After passing this test, the jumper must be removed and the on-site recycled water system connected to the recycled water

meter. Jumpers are prohibited at all times other than for performance of the cross-connection test.

The Cross-Connection test must be performed prior to the Customer receiving a temporary recycled water use permit and connecting to the recycled water meter. The testing is to be performed by the City and its certified Cross-Connection Control Specialist. The Customer's Site Supervisor is required to be present for the duration of the test.

The cross-connection testing procedure to be performed on the Customer's property by the City's certified Cross-Connection Control Specialist is outlined in **Section 4.3** of these Recycled Water Use Guidelines. If the test is passed, the Customer will receive a copy of a signed report documenting the test results. If the test fails, the Customer will be directed to perform the required corrective actions, and the test will need to be performed again.

Coverage Test: During the coverage test with recycled water, the City will inspect the irrigation portion of the Customer's on-site recycled water system to ensure that recycled water is only being applied within the approved use areas, and does not result in unintentional ponding, runoff, or overspray. The Customer's Site Supervisor is required to be present during the Coverage Test.

The City will complete a Coverage Test form (see **Appendix G**) following performance of the Coverage Test. Successful passage of the Coverage Test is required for the Customer to obtain a permanent Recycled Water Use Permit from the City. If any corrective actions are required to ensure that recycled water is applied only in the approved use area, the Customer will be directed to perform corrective maintenance of their system in a timely manner. The Customer is responsible for performing any required modifications to their irrigation system and any costs associated with those modifications. Following completion of corrective maintenance activities by the Customer, the City will re-conduct the Coverage test.

Record Drawings: The Customer, or Customer's contractor, must prepare record drawings to show the on-site recycled water system as constructed. These drawings must include all changes in the work constituting departures from the original contract drawings, including those involving both constant-pressure and intermittent-pressure lines and appurtenances, routing of indoor plumbing, and any information that shows where recycled water is being delivered on the Customer's property. All conceptual or major design changes must be approved by the City before implementing the changes in the construction contract. The recycled water system record drawings must be submitted to the City within ninety (90) days of the site receiving recycled water.

Final Approval: The City will grant final approval and issue a Recycled Water Use Permit after satisfactory completion of all of the following:

- Final inspection
- Cross-connection test
- Coverage test
- Submittal of record drawings for the Customer's on-site recycled water system
- Completion of Site Supervisor Training by the Customer's designated Site Supervisor



If these items are not completed within 90 days of the installation of the recycled water meter by the City, the City reserves the right to cancel the customer's application for recycled water service. The Customer will be required to pay for any costs associated with the City converting the water supply to the Customer's on-site recycled water system back to potable water.

Section 4. Operating and Maintaining Your On-Site Recycled Water System

Once a Customer's on-site recycled water system has been permitted by the City, it is the responsibility of the Customer to operate their system in accordance with these Recycled Water Use Guidelines. It is also the responsibility of the Customer to obtain City approval prior to any changes to their City approved on-site recycled water system. These changes include adding additional uses of recycled water, expanding the existing system, or changing how the system operates.

See **Appendix H** for Recycled Water Do's and Don'ts quick reference handout.

4.1. Site Supervisor Responsibilities

Each customer must designate a Recycled Water Site Supervisor to serve as the primary recycled water contact between the customer and the City. The City staff will provide training for the Recycled Water Site Supervisor prior to issuing a Use Permit and delivering water to the site. The following are the responsibilities of the Recycled Water Site Supervisor:

- Operate and maintain the on-site recycled water system
- Prevent and report violations for the on-site recycled water system
- Understand the requirements of these Recycled Water Use Guidelines relating to the safe use of recycled water and the maintenance of accurate records
- Ensure that there are no existing or potential cross-connections made between the potable and the recycled water systems
- Inform the City of all failures, violations and emergencies that occur involving the recycled or potable water systems
- Know the basic concepts of backflow and cross-connection prevention, system testing and related emergency procedures
- Train personnel at the use site on the proper uses of recycled water
- Conduct applicable monitoring and reporting to City as required by Order WQ 2016-0068 DDW, including completing the Quarterly Self Inspection Report (**Appendix F**)
- Check all recycled water identification signs, tags, stickers and above-grade pipe markings for their proper placement and legibility. Replace damaged, unreadable or missing signs, tags, stickers and pipe markings
- Periodically ensure that the on-site recycled water system does not have any broken sprinkler heads, faulty spray patterns, leaking or broken pipes, or other noted condition that violates the recycled water use requirements.
- Check spray patterns to eliminate ponding, runoff and windblown spray conditions. If evidence of ponding or runoff is noted, affected areas should be indicated on a sketch and sprinkler heads should be adjusted to prevent further ponding or runoff. County Health

regulations require that evidence of mosquitoes breeding within ponding should be noted and immediately eliminated

- Establish and maintain an accurate recordkeeping system of all inspections, modifications and repair work

Quarterly Self-Inspection Report: The Site Supervisor must complete a self-inspection report quarterly and submit the signed and completed report to the City. The Self-Monitoring Report must be submitted on or before March 15, June 15, September 15, and December 15 of each calendar year. The Quarterly Self-Inspection Report form will be provided to the Site Supervisor by the City. Failure of the Customer to submit the Quarterly Self-Inspection Report may trigger an on-site inspection by City staff or discontinuance of service. The Customer may be responsible for paying the City's costs to complete the inspection.

A copy of the Quarterly Self Inspection Report Form is attached to this document as **Appendix F**.

Change of Site Supervisor: If the designated Site Supervisor is relieved of his / her duties, the Customer must designate a new person to fulfill the role of Site Supervisor, and must have the new person attend Site Supervisor Training. Upon changing of the Site Supervisor, the Customer must contact the City within 30 days and provide the City with the contact information for the new Site Supervisor.

If the property is transferred to a new owner or tenant, or a new Site Supervisor or landscape company becomes responsible for system maintenance, the Customer must notify the City within 30 days in order to receive a new permit.

4.2. Customer Responsibilities

The Customer is responsible for maintaining and operating the on-site recycled water system downstream of the recycled water meter, which includes the following:

- Obtain all permits required for the design, construction, operation and maintenance of the on-site recycled water system
- Assign a Site Supervisor and ensure the Site Supervisor has obtained the required training
- Use recycled water in accordance with the City's Recycled Water Use Guidelines and the Customer's approved design plans
- Maintain the on-site recycled water system, including signs, markings and tags in accordance with all City Recycled Water Use Guidelines
- Ensure all materials used during the repair and maintenance of the system are approved or recommended for recycled water use
- Obtain prior authorization from the City before making any modifications to the approved recycled water system
- Report all violations and emergencies to the City

- Ensure that a Quarterly Self-Inspection Report is submitted to the City quarterly by the Customer's designated Site Supervisor

4.3. Cross-Connection Control Program

The City will perform a cross-connection test prior to the initial connection to the recycled water system to ensure that no connections exist or have the potential to exist between the potable water system and recycled water system. The customer's onsite Recycled Water Site Supervisor is required to be present to witness the cross-connection test.

The City is responsible for providing a Cross-Connection Control Specialist certified by the California-Nevada Section of the American Water Works Association. The Cross-Connection Control Specialist will be responsible for directing the test and completing the cross-connection test form.

The procedure for the test is generally outlined below. This test protocol may be customized for the site depending on how the potable and recycled water systems are plumbed.

Cross-Connection Control Test—Part One:

The potable water system shall be activated and pressurized. The recycled water irrigation system shall be shut down at its point of connection and depressurized—this is usually done by manually bleeding an irrigation control valve and/or quick-coupling valve that is located at the lowest point of elevation in the irrigation system.

1. The potable water system shall remain pressurized for a minimum period of time specified by the cross-connection specialist while the irrigation system is depressurized. The minimum period of time the recycled water irrigation system is to remain depressurized shall be determined on a case-by-case basis, taking into account the size and complexity of the potable water and recycled water irrigation systems.
2. All recycled water irrigation control valves and quick-coupling valves, and any site features that are approved to be supplied with recycled water from the on-site irrigation system (such as decorative fountains) shall be tested and inspected for flow. If the recycled water system has been successfully shut down at its point of connection, then continuous flow from any part of the recycled water system — irrigation system or decorative fountains, etc. — indicates a cross-connection.
3. All potable water fixtures (interior and exterior)—faucets, hose bibs, drinking fountains, toilets and urinals, supply lines to decorative fountains, etc.—shall be tested and inspected for flow. No flow from any potable water outlet indicates that it may be connected to the recycled water irrigation system.
4. If no cross-connections are discovered, proceed to the Part Two of the test. If any cross-connections are found, they must be disconnected, and the site must be retested by an AWWA cross-connection specialist per these procedures.

Cross-Connection Control Test—Part Two:

1. The potable water system shall be shut down at its point of connection (usually the meter) and depressurized. In the case of a potable water system in a multi-story building, the potable water system pressure may be reduced by the amount deemed necessary by the cross-connection specialist and monitored with a gauge installed at a low point of elevation in the potable water system.
2. The recycled water irrigation system shall then be activated and pressurized.
3. The recycled water irrigation system shall remain pressurized for a minimum period of time specified by the cross-connection control specialist while the potable water system is depressurized (or, in the case of a multi-story building potable water system, remains in a state of reduced pressure). The minimum period of time the potable water system is to remain depressurized shall be determined on a case-by-case basis.
4. All potable water fixtures (interior and exterior)—faucets, hose bibs, drinking fountains, toilets and urinals, supply lines to decorative fountains, etc.—shall be tested and inspected for flow. Some flow may occur from water breaking loose from an air lock in an overhead water line. The amount of flow to cause a concern is a judgment call by the cross-connection specialist. If the potable water system has been successfully shut down at its point of connection, then continuous flow from any part of the potable water system (that is beyond the drainage generated by an air lock breaking free) indicates a cross-connection. In the case of a potable water system in a multi-story building, the testing of all fixtures may be used in combination with a pressure gauge (mentioned in No. 1 above), or the pressure gauge may be used instead of the testing of all fixtures. If the potable water system has been truly shut down at its point of connection, then an increase in the potable water system pressure viewed at the gauge over a period of time specified by the cross-connection specialist indicates a cross-connection.
5. All recycled water irrigation control valves and quick-coupling valves, and any other site features that are approved to be supplied with recycled water from the on-site irrigation system (such as supply lines to decorative fountains) shall be tested and inspected for flow. No flow from a recycled water irrigation control valve, quick-coupling valve or any other recycled water fixture indicates that it may be connected to the potable water system.
6. If no cross-connections are discovered, then the potable water system shall be repressurized. If any cross-connections are found, they must be disconnected and the site must be retested by an AWWA cross-connection specialist per these procedures.

The certified AWWA cross-connection control specialist responsible for completing the above test will indicate the results on a City Water Recycling Cross-Connection Certification Form and return it to the City. A representative from the City will witness and/or perform the cross-connection test.

4.4. Emergency Procedures

In case of earthquake, flood, fire, major freeze, nearby construction or other incident, which could cause damage to the recycled or potable water systems, the Site Supervisor must inspect the potable and recycled water systems for damage as soon as it is safe to do so. If either system appears damaged, both the domestic and recycled water systems should be shut off at their points of connection. The Site Supervisor must immediately contact the City for further instruction.

To prevent contamination, damage or a public health hazard, the Customer may make emergency modifications or repairs without the prior approval of the City. As soon as possible after the modification (but within three days), the Customer must notify the City of the emergency modifications and file a written report.

The Site Supervisor must immediately notify the City of any failure of backflow device or plumbing system or cross-connections between the recycled water and potable water system, whether or not it is believed a violation has occurred. The Site Supervisor must also notify the City of any violation that might occur because of any action the Customer's personnel might take during the operation of the recycled water or potable water systems. If there are any doubts whether a violation has occurred, the Site Supervisor must report each occurrence to the City, so a decision can be made as to the need for further action.

If, due to a cross-connection on the Customer's premises, contamination of the potable water system is suspected or known, the Customer must immediately notify the City. The Customer must immediately invoke the following steps.

1. **The Customer must notify the City immediately.** This notification must be followed by a written notice within 24 hours that includes an explanation of the nature of the cross-connection, date and time discovered, and the contact information of the person reporting the cross-connection.
2. The City will notify DDW of the reported cross-connection.
3. The Customer must immediately shut down the recycled water supply to the facility.
4. The Customer must keep the potable system pressurized and post "Do Not Drink" signs at all potable water fixtures and outlets.
5. The Customer must provide bottled water for employees until the potable water system is deemed safe to drink.
6. The Customer must follow the procedures outlined by City and DDW

The City will bring the recycled water system back into service only as directed by the DDW. Only after they have informed the City and obtained the City's approval that potable water can be consumed on-site again, can the Customer remove the "Do Not Drink" signs from all potable water fixtures and outlets.

For emergencies during business hours, Monday thru Friday from 7:30 AM to 4:00 PM, contact the Water Distribution office at (510) 881-7933.

For emergencies during non-business hours, contact Police Dispatch at (510) 293-7000.

Appendix A – Definitions and Abbreviations

Appendix A. Definitions and Abbreviations

Whenever the following terms (or pronouns used in their place) or abbreviations occur in this document, their intent and meaning shall be interpreted as follows:

Abbreviations

AWWA	American Water Works Association
City	City of Hayward
DDW	Division of Drinking Water
EBDA	East Bay Dischargers Authority
NOA	Notice of Applicability
NOI	Notice of Intent
RCEC	Russell City Energy Center
RWF	Recycled Water Facility
RWQCB	San Francisco Bay Regional Water Quality Control Board
State Water Board	California State Water Resources Control Board
Title 22	California Code of Regulations, Title 22
Use Permit	Recycled Water Use Permit
WPCF	Water Pollution Control Facility

Definitions

Air Gap. A physical separation between the free-flowing discharge end of a water supply pipeline and an open or non-pressurized receiving vessel. An approved air gap must be at least twice the diameter of the water supply pipe measured vertically above the overflow rim of the vessel, and in no case less than 1".

Approved Use. An application of recycled water in a manner, and for a purpose, designated in a Recycled Water Use Permit issued by the City and in compliance with all applicable requirements.

Approved Use Area. A site with well-defined boundaries designated on the approved Drawings to receive recycled water.

Cross-Connection. Any actual or potential physical connection between any part of a water system used or intended to supply water for drinking purposes and any source or system containing water or substance that is not or cannot be approved for human consumption. This includes direct piping between the two systems, regardless of the presence of valves, backflow prevention devices or other appurtenances.

Customer. Any person, persons or firm, including any public utility, municipality or other public body or institution issued a Recycled Water Use Permit by the City. The customer may be the owner, tenant or property manager, as appropriate.

Intermittently Pressurized Line. Also known as a "lateral," it is the pipe section(s) between the control valve and the sprinkler head or drip emitters.

Landscape Impoundment. A body of recycled water used for aesthetic enjoyment or which otherwise serves a function not intended to include public contact.

On-site. Designates or relates to facilities owned and operated by the Customer.

Overspray. The spray of recycled water outside the approved irrigation area.

Operations Personnel. Any employee of a customer, whether permanent or temporary, or any contracted worker whose regular or assigned work involves the supervision, operation or maintenance of equipment on any portion of on-site facilities using recycled water.

Point of Connection. The point where the customer's system ties to the City's system, usually at the water meter.

Ponding. Retention of recycled water on the surface of the ground or other natural or manmade surface for a period following the cessation of an approved recycled water use activity.

Potable Water. Water that is authorized for human consumption according to the latest edition of the California Safe Drinking Water Act or other applicable standards.

Public. Any person or persons, other than the site owner or employees, who may come in contact with facilities and/or areas where recycled water is approved for use.

Rate and Fee Schedule. The schedule of all rates, charges, fees and assessments to be made concerning the use of recycled water served by the City.

Recycled Water. As defined in the California Code of Regulations (CCR), Title 22, Division 4, Chapter 3, "Water Recycling Criteria", recycled water is considered to be of the type considered to be "disinfected tertiary recycled water." This quality of recycled water can be used for all approved nonpotable water uses.

Recycled Water Use Permit. A permit issued by the City to the customer which outlines monitoring, self-inspection, reporting and site-specific requirements.

Reduced Pressure Principal Backflow Prevention Device. A type of backflow prevention device, usually installed near a water meter, which prevents backflow by a combination of double-check valves and a pressure-differential-relief valve with a resilient-seated shutoff valve on each end of the device.

Regulatory Agencies. Those public agencies legally constituted to protect the public health and water quality, such as the State Department of Public Health (DPH), the Regional Water Quality Control Board (RWQCB), State Water Resources Control Board (SWRCB) and the County Public Health Department.

Runoff. Recycled water which drains outside the approved irrigation area.

Service. The furnishing of recycled water to a customer through a metered connection to the on-site facilities.

Site Supervisor. The responsible person designated by the customer to be a liaison with the City. This person must have the authority to carry out any requirements of the City, must be responsible for the operation and maintenance of the recycled water system, and must prevent potential violations.

Unauthorized Discharge. Any release of recycled water that violates the Rules and Regulations of the City or applicable Federal, State or local statutes, regulations, ordinances, contracts or other requirements.

Violation. Noncompliance with any condition or conditions of the Recycled Water Use Permit by any person, action or occurrence, whether willfully or by accident.

Water Retailer. The local purveyor of recycled water for the specified service area (public or private); in this case, the City Hayward.

Windblown Spray. Dispersed, airborne particles of recycled water that can be transmitted through the air to locations other than those approved for the direct application of recycled water.

Appendix B – City of Hayward Municipal Code for Recycled Water Use

ARTICLE 6 - RECYCLED WATER USE^[10]

Footnotes:

--- (10) ---

Note— Ordinance 15-33 adding Article 6 to Chapter 11 of the Hayward Municipal Code regarding Recycled Water Use, adopted December 15, 2015.

SEC. 11-6.1 - FINDINGS.

The policies described above are in the best interest of the City of Hayward. This ordinance is necessary to protect the common water supply of the region, which is vital to public health and safety. The City is highly dependent on limited supplies of imported water for domestic, irrigation and industrial uses. The reliability of the supply of imported water is uncertain, particularly during years of drought conditions, and by developing and utilizing recycled water, the reliance on imported water can be reduced. In light of these circumstances, certain uses of potable water may be considered unreasonable where recycled water is available.

SEC. 11-6.2 - RECYCLED WATER POLICY.

It is the policy of the City that recycled water determined to be available pursuant to Section 13550 of the Water Code shall be used for nonpotable uses within the designated Recycled Water Service Areas, to be set forth within the jurisdiction consistent with legal requirements, preservation of public health, safety and welfare, and the environment.

SEC. 11-6.3 - DEFINITIONS.

The following terms are defined for the purposes of this ordinance:

- (1) Artificial Lake - A human-made lake, pond, lagoon, or other body of water that is used wholly or partly for landscape, scenic or noncontact recreational purposes.
- (2) Commercial - Any building for office or commercial uses with water requirements which include, but are not limited to, landscape irrigation, toilets, urinals and decorative fountains.
- (3) Industrial Process - Water used by any industrial facility with process water requirements which include, but are not limited to, rinsing, washing, cooling and circulation, or construction, including any facility regulated by the industrial waste discharge ordinance of Hayward.
- (4) Irrigation - Water used for landscape maintenance, including but not limited to landscaping of streets and medians, golf courses, cemeteries, common landscaped areas and parks.
- (5) Potable Water - Water which conforms to the federal, state and local standards for human consumption.
- (6) Recycled Water - Water which, as a result of treatment of wastewater, is suitable for a direct beneficial use or controlled use that would not otherwise occur. (See Water Code Section 13050(n).)

SEC. 11-6.4 - RECYCLED WATER SERVICE AREAS.

The City shall prepare and adopt Recycled Water Service Areas to define, encourage, and develop the use of recycled water where the City can or may in the future use recycled water in lieu of potable water. The following provisions shall apply to the Recycled Water Service Areas:

- (1) Establishment of Recycled Water Service Areas. The Recycled Water Service Area shall be established based upon evaluation of the location and size of present and future wastewater treatment facilities, distribution pipelines, pump stations, storage facilities and other related recycled water facilities.
- (2) Types of Uses of Recycled Water in Recycled Water Service Areas. Recycled water uses within the Recycled Water Service Areas may include, but are not limited to, the irrigation, filling of artificial lakes, and appropriate industrial and commercial uses.
- (3) Mandatory Recycled Water Use in Recycled Water Service Areas. Irrigation, filling of artificial lakes, and appropriate industrial process and commercial uses within the Recycled Water Service Areas shall be limited to the use of recycled water, unless a waiver is granted by the City as specified in Section 5 of this Ordinance.

SEC. 11-6.5 - MANDATORY RECYCLED WATER USE BY EXISTING WATER USERS.

The following provisions shall govern the mandatory use of recycled water by existing water users:

- (1) Preliminary Determination. The City shall evaluate each existing customer's water use within the recycled water service areas and make a preliminary determination as to whether irrigation, commercial or industrial processes or filling of artificial lakes shall be converted to the use of recycled water. Each affected water customer shall be notified of the basis for a determination that conversion to recycled water will be required, as well as the proposed conditions and schedule for conversion.
- (2) Notice. The notice of the preliminary determination, including proposed conditions and schedule for compliance, price of recycled water, and customer responsibilities will be sent to the water customer by certified mail.
- (3) Appeals. The water customer may appeal the City's preliminary determination within 30 days after a notice of determination is delivered or mailed to the customer. The customer may request reconsideration of the determination, or modification of the proposed conditions or schedule. The reasons for the appeal must be specified in writing. The City staff shall review the appeal and shall confirm, modify or abandon the preliminary determination.

SEC. 11-6.6 - RECYCLED WATER USE BY NEW DEVELOPMENTS.

The following provisions shall govern the mandatory use of recycled water in new developments:

- (1) Preliminary Determination. Upon application by a developer, owner or water customer (herein referred to as "applicant") for a new industrial or commercial facility or residential subdivision located within the designated Recycled Water Service Areas, the staff shall make a preliminary determination whether the proposed use of the subject property is required to be served with recycled water or to include facilities designed to accommodate the use of recycled water in the future. Based upon such determination, use of recycled water and provision of recycled water distribution systems or other facilities for the use of recycled water, and application for a permit for such use shall be required as a condition of approval of any such application, in addition to any other conditions of approval.
- (2) Alterations and Remodeling. On a case by case basis, upon application for a permit for the alteration or remodeling of multi-family, commercial or industrial structures (including, for example, commercial office buildings) within the Recycled Water Service Areas, the staff shall make a preliminary determination whether the subject property shall be required to be served with recycled water or to include facilities designed to accommodate the use of recycled water in the future. Based upon such determination, use of recycled water and provision of recycled water distribution systems or other facilities for the use of recycled water, and application for a permit for such use, may be required as a condition of approval of the application.
- (3) Final Notice of Determination. Prior to final approval of the development application, applicants shall be provided with a final determination of whether the proposed use of the subject property

is required to be served with recycled water or to include facilities designed to accommodate the use of recycled water in the future as a condition of approval.



- (4) Temporary Use of Potable Water. At the discretion of the City, potable water may be made available to new development on a temporary basis, until recycled water is available.

Appendix C – Recycled Water Service Area Map

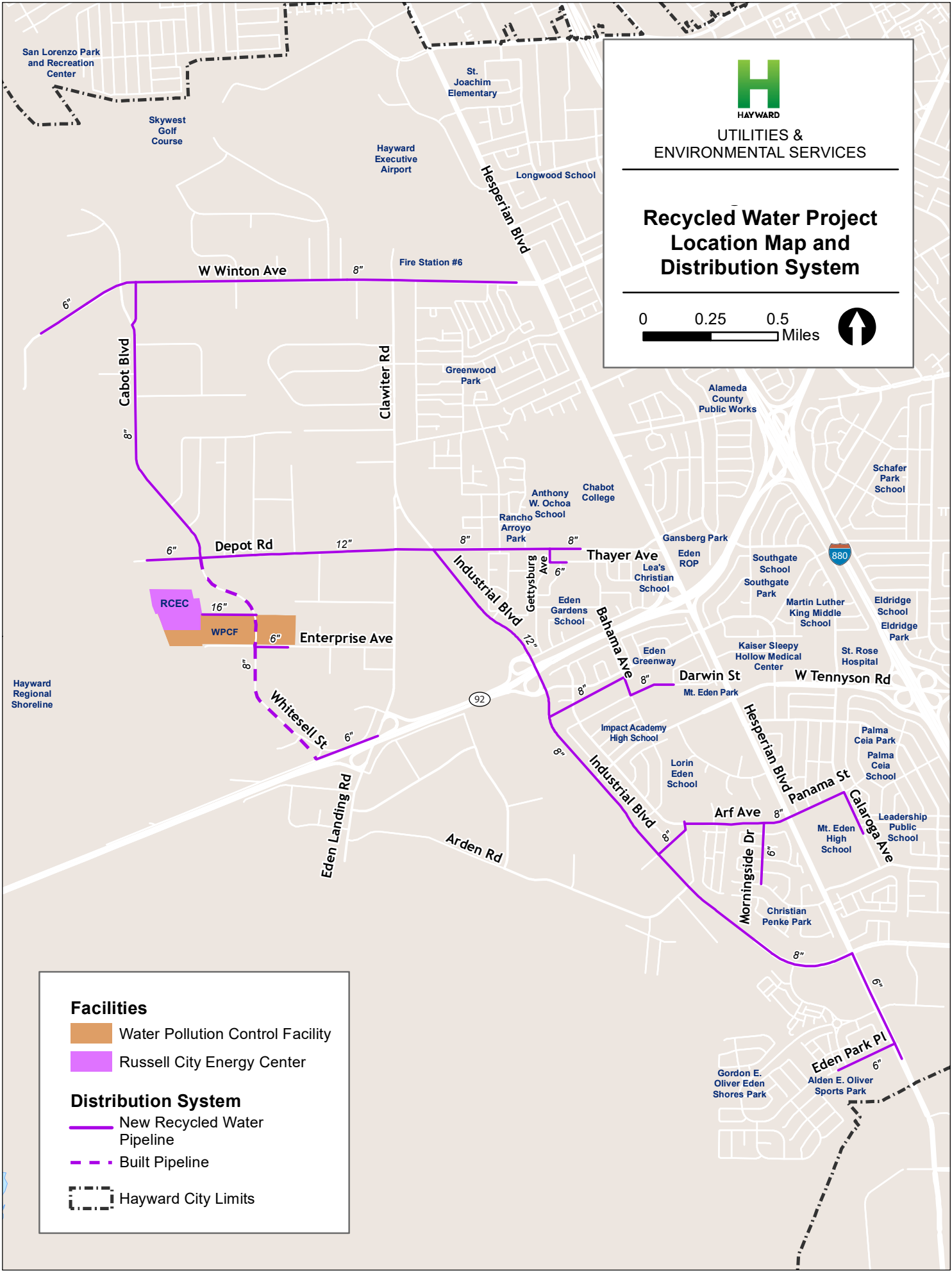
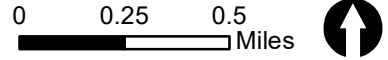

**Recycled Water Project
 Location Map and
 Distribution System**



Facilities

-  Water Pollution Control Facility
-  Russell City Energy Center

Distribution System

-  New Recycled Water Pipeline
-  Built Pipeline
-  Hayward City Limits

Appendix D – Usage Application and Permit (Sample)

RECYCLED WATER SERVICE PERMIT APPLICATION

Date: _____
 Site Name: _____ APN: _____
 Service Address: _____
 Location or Brief Legal Description of Site: _____
 Type of Property (e.g., office building): _____
 Expected Date to Commence Recycled Water Service: _____

Customer: _____	Proposed Site Supervisor: _____
Contact Name: _____	Company / Organization: _____
Mailing Address: _____	Mailing Address: _____
City: _____	City: _____
State: _____ Zip: _____	State: _____ Zip: _____
Phone: () _____	Phone: () _____
Email: _____	Email: _____
	24-Hour Phone: () _____

Brief description of proposed Site Supervisor's current responsibilities and familiarity with the future recycled water system:

Brief description of proposed recycled water use(s):

Estimated recycled water requirements:	Area (SQ FT) or Size (COUNT)	Annual Demand (CCF)	Peak Demand (GPM)
Landscape Irrigation:	_____	_____	_____
Toilets / Urinals:	_____	_____	_____
Cooling:	_____	_____	_____
Other: _____	_____	_____	_____

This is a: new existing service.

Existing City Recycled Water Account No.(s): _____

Existing City Potable Water Account No.(s): _____

Is the potable system proposed to operate as back-up? yes no

Is an on-site pump proposed? yes no



Plans, Specifications and Supporting Documents

For both new and existing services, plans, specifications and other necessary supporting documents must be submitted with this application for service. The plans, specifications and supporting documents must be sufficient to demonstrate that the facility will comply with the "City of Hayward Recycled Water Customer Guidelines." A copy of these rules is available online at:

<http://www.hayward-ca.gov/your-government/departments/utilities-environmental-services/recycled-water>

I understand and agree to all conditions for recycled water service as set forth in the City of Hayward’s municipal code and Recycled Water Customer Guidelines and hereby certify under penalty of perjury that the information provided in this application and in any attachments is true and accurate to the best of my knowledge. I also certify that I have read and agree to abide by all conditions specified by the City of Hayward’s recycled water program.

CUSTOMER: _____ TITLE: _____
(SIGNATURE)

_____ DATE: _____
(PRINT NAME)

For City Use Only

Date	Action	Verified by
	Permit Application Completed	
	Water Service Application Completed	
	Dual-Plumbing Engineering Report Completed <i>(Indoor or Single-Residence Irrigation Uses Only)</i>	
	Plan Check Completed <i>(New Services Only)</i>	
	Construction Inspection Completed <i>(New Services Only)</i>	
	Cross-connection Test Completed	
	Meter Installed <i>(New Services Only)</i>	
	Coverage Test Completed	
	Temporary Permit Issued	
	Site Supervisor Training Certification Received	
	Record Drawings Received <i>(New Services Only)</i>	
	Final Permit Issued	

RETURN COMPLETED APPLICATION TO:

City of Hayward
Public Works & Utilities Department – Recycled Water Program
777 B Street – Hayward, CA 94541
Phone: 510.583.4700 – Fax: 510.583.3610

RECYCLED WATER USE PERMIT

The recycled water customer shall keep a copy of this Use Permit and must present it to the City of Hayward (City)/State Water Control Board (State Board) Division of Drinking Water, or Regional Water Quality Control Board/staff upon request. This permit is subject to all prohibitions, specifications and provisions of the State Board General Water Reclamation Requirements for Recycled Water Use and the City's Recycled Water Use Ordinance.

Customer shall immediately notify the City if a new Recycled Water Supervisor is appointed so that proper training can be provided.

Customers shall follow the City's Recycled Water Use Guidelines, including submitting Quarterly Self-Monitoring Reports to the City of Hayward. Failure to comply with the City's Recycled Water Use Guidelines may result in termination of recycled water service.

CUSTOMER SITE INFORMATION

Customer Name: _____

Address: _____

Phone: _____ Fax: _____

Property Owner/Contact Name: _____

Property Owner Phone: _____

USAGE INFORMATION

Estimated recycled water use per year: _____ acre/feet

Use of application site: _____

Location of use: _____

AUTHORIZATION*

Customer is authorized to use recycled water for the application listed above in accordance with this permit. Customer has received training on proper use of recycled water and has been given a copy of the City's Recycled Water Use Guidelines.

Authorizing Signature: _____ Date: _____

Name: _____

Title: _____

Phone Number: _____

*This document supersedes all prior Use Permits.

Appendix E – Standard Details

FOR DEVICE LABELING
WARNING TAG INFORMATION
SEE DET A/D2

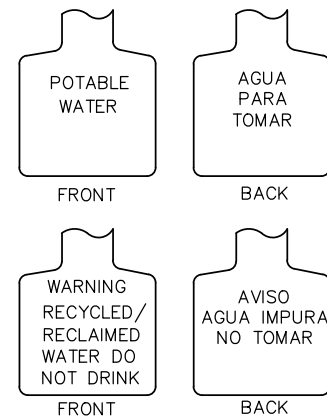

IDENTIFY
WATER
USAGE
DEVICE

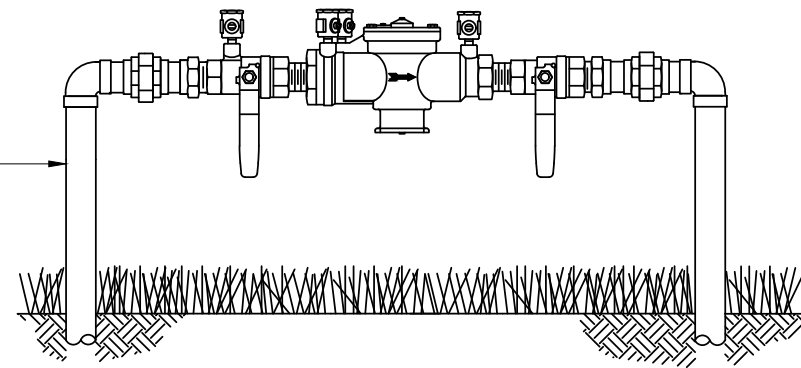

NOTE: ALL WATER METERS, AIR/VACUUM RELIEF VALVES, VALVES, PRESSURE REDUCING VALVES, PUMPS, PUMP CONTROL VALVES, ETC., SHALL BE TAGGED OR LABELED INDICATING WHETHER THE DEVICES ARE ON RECYCLED WATER OR POTABLE WATER SYSTEM.

WATER CONTROL DEVICE DETAIL

NOT TO SCALE

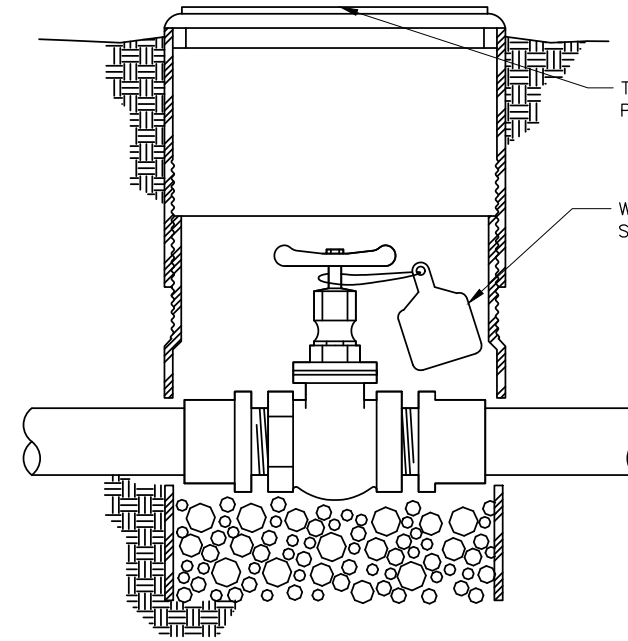

TOP OF LID TO BE LABELED
PER DET C/D1

WARNING TAG
SEE DET A/D2

GATE VALVE DETAIL

NOT TO SCALE



IRRIGATION VALVE BOX NOTES:

- FOR NEW INSTALLATIONS, INSTALL CARSON PURPLE IRRIGATION VALVE BOXES (OR EQUAL) THAT ARE USED FOR RECYCLED WATER APPLICATIONS. BOXES SHALL BE IMPRINTED WITH THE INFORMATION THAT IS SHOWN ON THE VALVE BOX NAMEPLATE. SEE RIGHT >

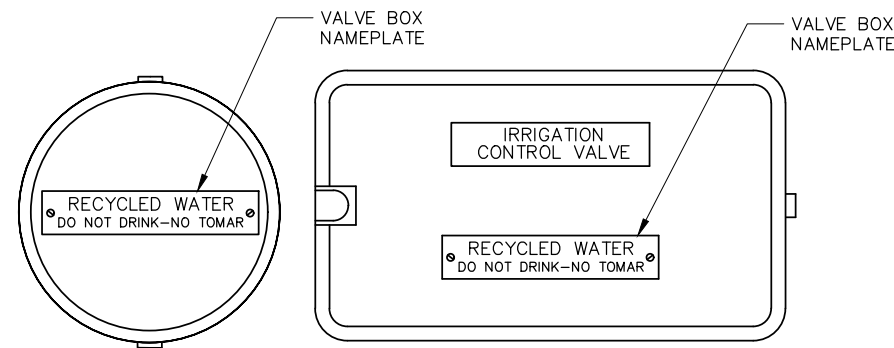

VALVE BOX NAMEPLATE INFO: T. CHRISTY ENTERPRISES, INC. CATALOG P/S: 3800 (OR EQUAL).

IRRIGATION BOX COVERS/LIDS DETAIL

NOT TO SCALE

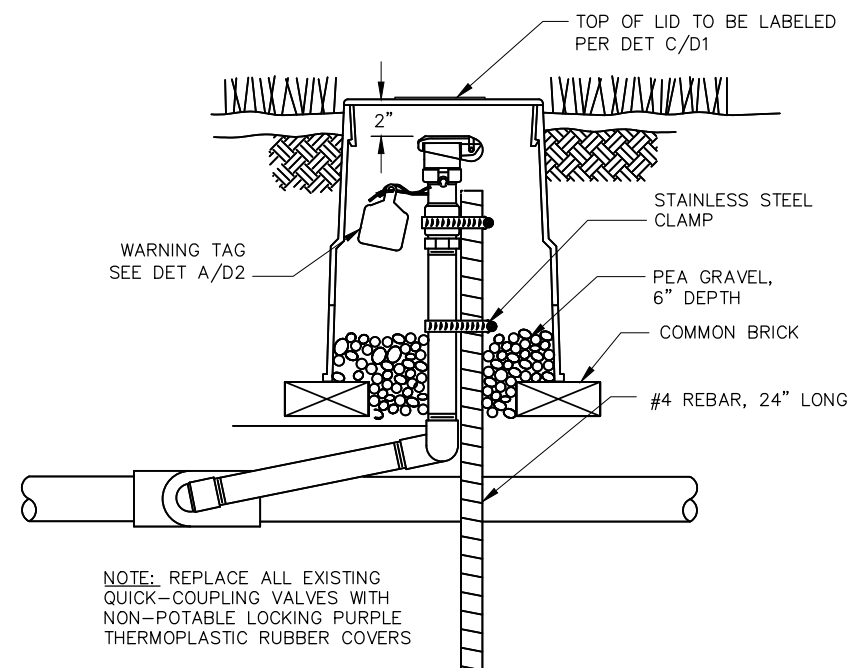

NOTE: REPLACE ALL EXISTING QUICK-COUPLING VALVES WITH NON-POTABLE LOCKING PURPLE THERMOPLASTIC RUBBER COVERS

QUICK COUPLING VALVE DETAIL

NOT TO SCALE

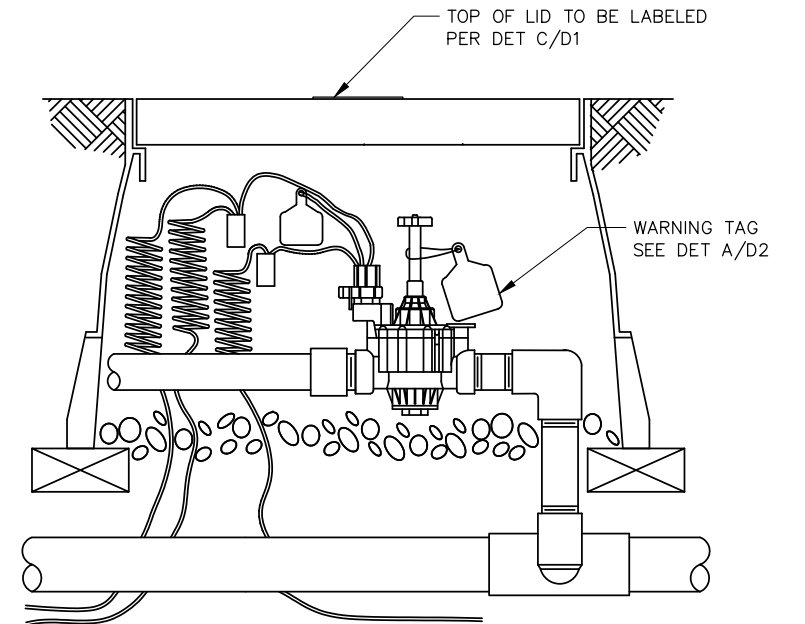

REMOTE CONTROL VALVE DETAIL

NOT TO SCALE

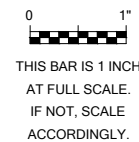

JOB NO. 419-001
DATE MAY 2017
DRAWN BY Drawn 1
DESIGNED BY Designer 1
PROJ. MGR. Proj. Mgr.

ZONE	REV	DESCRIPTION	DATE	APVD
REVISIONS				

**CITY OF HAYWARD
RECYCLED WATER
PROGRAM**

STANDARD DETAILS

**IRRIGATION VALVES AND BOXES
STANDARD DETAILS 1**

D1

DRAWING NUMBER

SHEET 1 OF 6

RECYCLED WATER
RECYCLED WATER COLOR: PURPLE

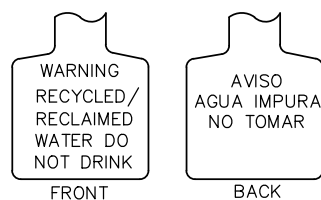

SAMPLE WARNING TAG. BACKGROUND PURPLE (PANTONE 512) WITH BLACK LETTERING.
NOTE: T CHRISTY ENTERPRISES INC. P/N: ID-MAX-P2-RC006 (OR EQUAL)

POTABLE WATER
DRINKING WATER COLOR: BLUE

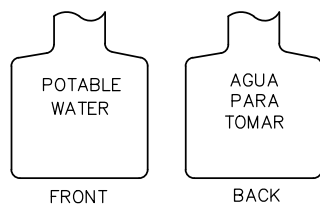

NOTE: T CHRISTY ENTERPRISES INC. P/N: ID-MAX-P2-RCXXX (OR EQUAL)

WARNING TAG INFORMATION

NOT TO SCALE

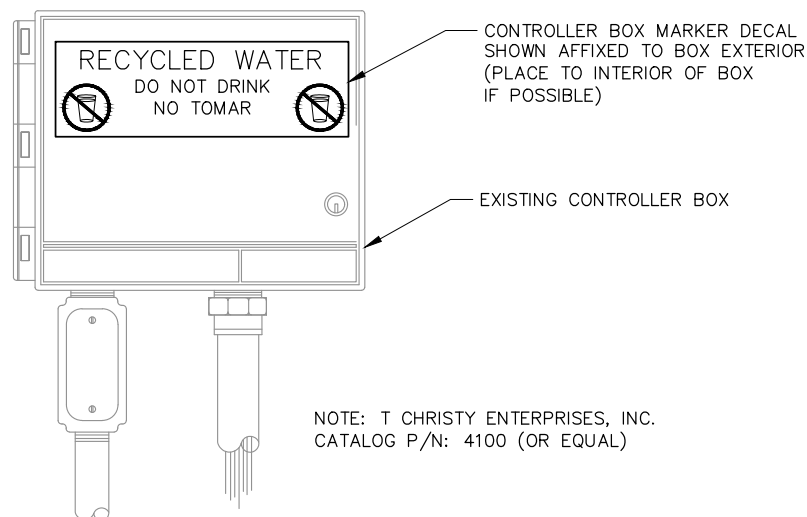

NOTE: T CHRISTY ENTERPRISES, INC. CATALOG P/N: 4100 (OR EQUAL)

CONTROLLER BOX MARKER DETAIL

NOT TO SCALE

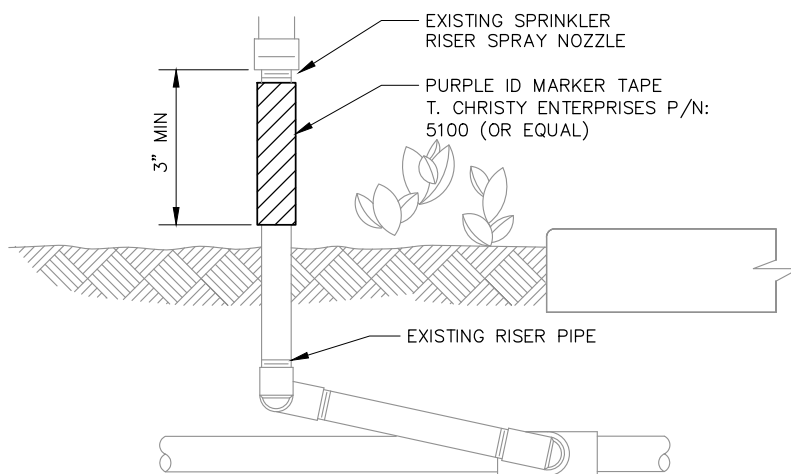

RECYCLED WATER RISER MARKER DETAIL

NOT TO SCALE

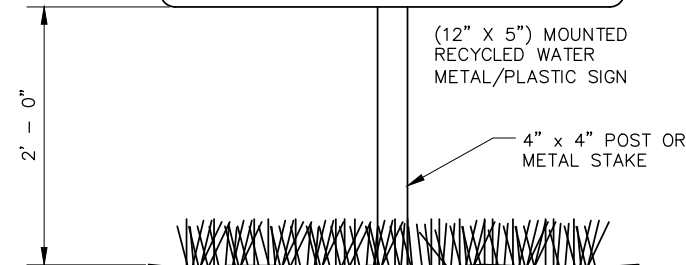

ADVISORY SIGN DETAIL

NOT TO SCALE



8" X 4" CUSTOMER INSTALLED SIDEWALK SIGN ACCEPTABLE FOR USE IN HIGH VANDALISM AREAS. INSTALLATION AREAS INCLUDE: SIDEWALKS AND CONCRETE WALKWAYS ENTERING SITES.

NOTE: EACH SIGN TYPE TO BE OBTAINED FROM THE CITY OF HAYWARD.

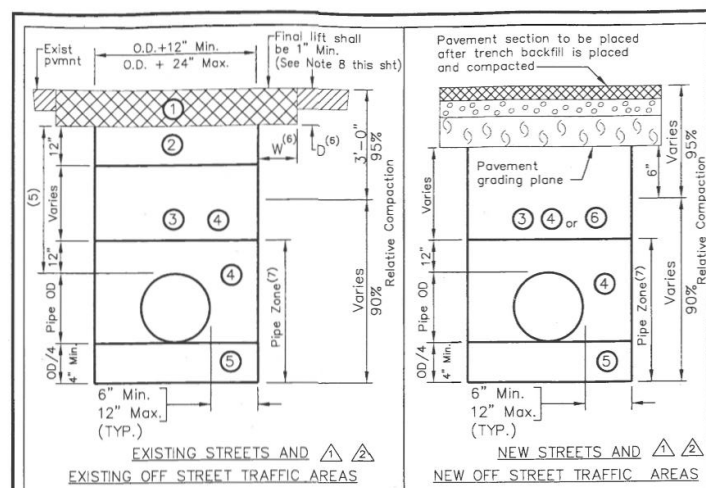

BEDDING CLASS AND BACKFILL MATERIALS		
BEDDING CLASS	Material	COMPACTION METHOD
LOAD FACTOR	1.9 (1)	
MATERIAL LOCATION	① Asphalt Concrete (Type A, 1/2" Max., Medium Grading)	Mechanical
	② Class 2 Aggregate Base	Mechanical
	③ Class 2 Aggregate Subbase(2)	Mechanical
	④ Quarry Fines(2) or Class 2 Agg. Sub.(2)	Mechanical
	⑤ Quarry Fines, Class 2 Agg. Sub.(2) or Drain Rock(3)	Mechanical
	⑥ Native Material(4) or Class 2 Aggregate Subbase	Mechanical

(1) See Note 1 on sheet 3.
(2) See Note 2 on sheet 3.
(3) See Note 3 on sheet 3.
(4) See Note 4 on sheet 3.
(5) When this dimension is less than 2'-0", material location ⑥ governs.
(6) See Table on sheet 2 for "D" and "W" dimension. The "D" and "W" dimensions shall be the same on both sides of the trench.
(7) See Note 12 on sheet 3.
(8) See SD-126 for pavement mitigation for streets on moratorium.

HAYWARD PUBLIC WORKS DEPT.
STANDARD PERMIT AND SUBDIVISION TRENCH SECTIONS
DWG. NO. **SD-125**
REV. DATE BY: [Signatures]
SHEET 1 OF 3

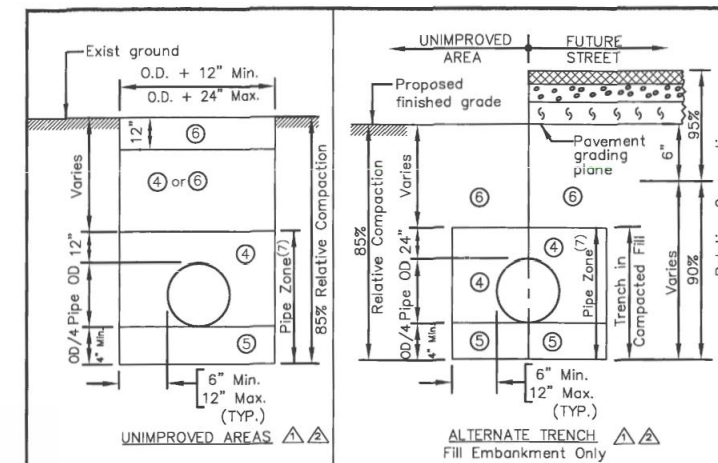

STREET TYPE	Transverse Trench		Longitudinal Trench	
	D	W	D	W
Primary Thoroughfares, Major Streets, Industrial Service Roads	12"	12"	12"	12"
Collector Streets and all Minor Street Bus Routes	12"	12"	8"	12"
Minor Streets	8"	12"	4"	12"
Off Street Traffic Areas	In Kind	0"	In Kind	0"

QUARRY FINES & DRAIN ROCK SPECIFICATIONS		
Sieve Sizes	Percentage Passing Sieve	
	Quarry Fines	Drain Rock
1"	100	100
3/4"	95-100	95-100
NO. 4	40-90	0-25
NO. 30	15-40	0-5
NO.200	5-20	0
DURABILITY 40		

HAYWARD PUBLIC WORKS DEPT.
STANDARD PERMIT AND SUBDIVISION TRENCH SECTIONS
DWG. NO. **SD-125**
REV. DATE BY: [Signatures]
SHEET 2 OF 3

CITY OF HAYWARD TRENCH DETAIL

NOT TO SCALE

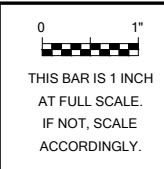

JOB NO. 419-001
DATE MAY 2017
DRAWN BY Drawn 1
DESIGNED BY Designer 1
PROJ. MGR. Proj. Mgr.

ZONE	REV	DESCRIPTION	DATE	APVD

CITY OF HAYWARD RECYCLED WATER PROGRAM

STANDARD DETAILS

SIGNAGE, TAGS, AND MARKERS IRRIGATION STANDARD DETAILS 2

D2
DRAWING NUMBER
SHEET 2 OF 6

A B C D E F G H

6

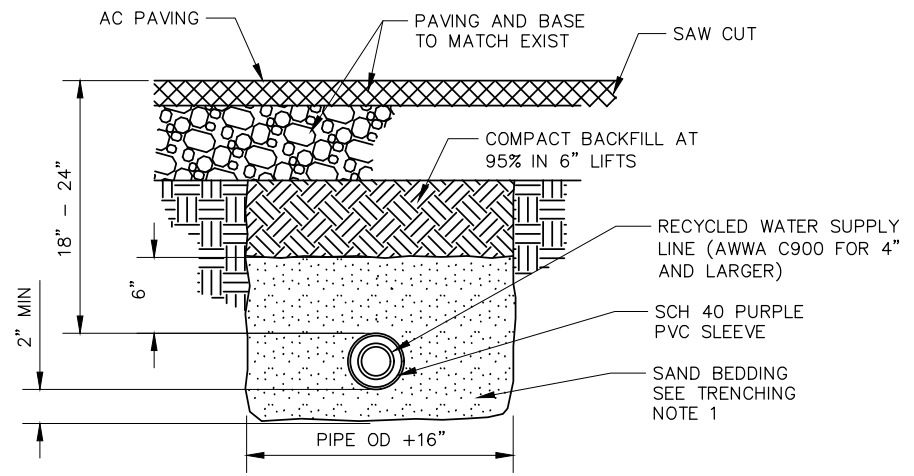

CONDITION 1: UNDER NON-VEHICULAR TRAFFIC PAVING (SEE NOTE 6)

5

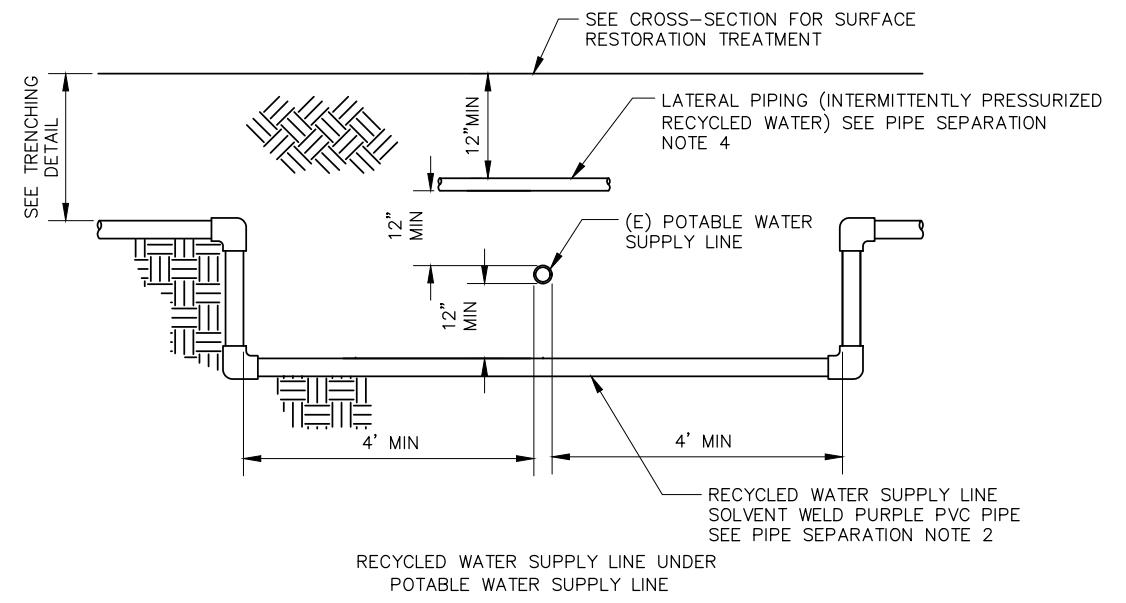

- TRENCHING NOTES:**
- SAND BEDDING REQUIRED IN TRENCHING WITH ROCKY TERRAIN AND UNDER THE PAVEMENT.
 - SALVAGE EXCAVATED BACKFILL—COMPACT.

- PIPE SEPARATION NOTES:**
- RECYCLED WATER PRESSURE MAIN LINE PIPING MUST BE LOCATED A MINIMUM OF 12 INCHES BELOW THE POTABLE WATER SUPPLY LINES AND A MINIMUM 10 FEET HORIZONTAL CLEARANCE ON EITHER SIDE.
 - THE MINIMUM HORIZONTAL SEPARATION CAN BE REDUCED TO 4 FEET IF ANY OF THE FOLLOWING CRITERIA ARE MET:

- A: SOLVENT WELD PVC PIPE ON RECYCLED WATER SYSTEM.
- B: RESTRAINED PVC PIPE FOR RECYCLED OR POTABLE IF LARGER THAN 4 INCHES.
- C: RESTRAINED DUCTILE IRON PIPE ON RECYCLED WATER SYSTEM.
- D: SOLDER COPPER PIPE ON RECYCLED WATER SYSTEM.
- E: SLEEVE POTABLE PIPE.
- F: SLEEVE RECYCLED PIPE.

4

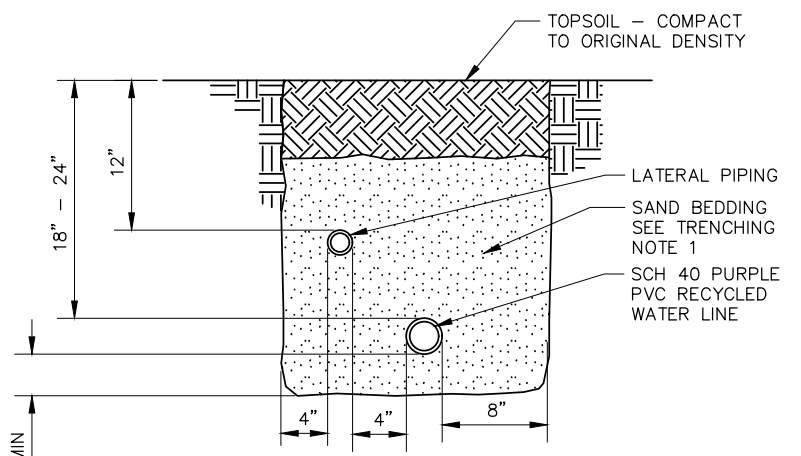

CONDITION 2: AT PLANTER IN ROCKY TERRAIN

3

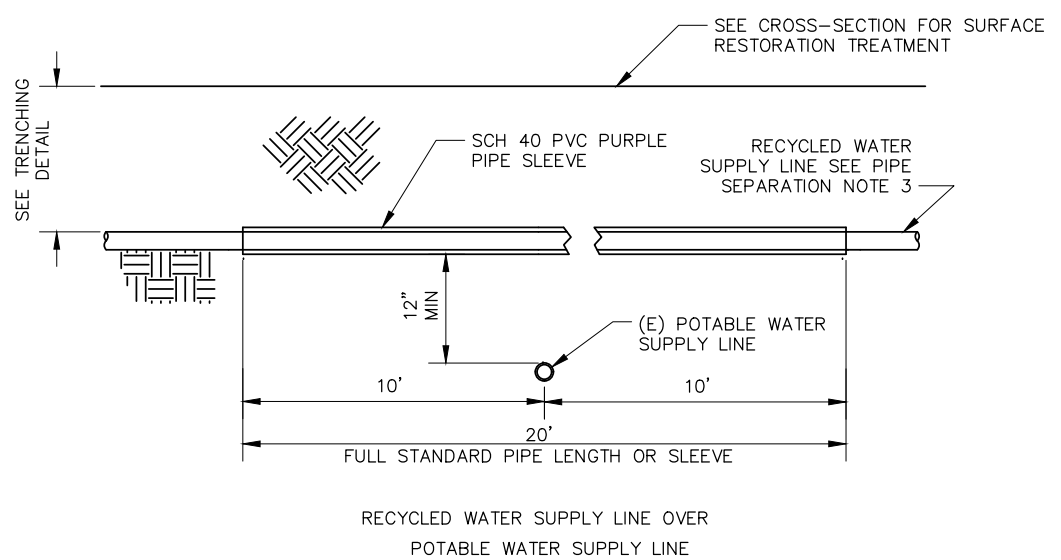

DETAIL C
NOT TO SCALE

- RECYCLED WATER PRESSURE MAIN LINE PIPELINES ARE ALLOWED OVER POTABLE PIPELINES WITH A MINIMUM OF 12 INCHES VERTICAL SEPARATION IF A FULL STANDARD PIPE LENGTH IS CENTERED OVER THE CROSSING, OR THE RECYCLED PIPELINE IS SLEEVED FOR THE SAME LENGTH.
- RECYCLED WATER LATERALS (INTERMITTENTLY PRESSURIZED PIPELINES) ARE ALLOWED TO CROSS OVER POTABLE WATER PIPELINES WITH A MINIMUM OF 12 INCHES VERTICAL SEPARATION.
- SEWER PIPE MUST BE 12 INCHES BELOW RECYCLED WATER LINE.
- NON-VEHICULAR TRAFFIC PAVING SUCH AS CONCRETE OR ASPHALT PAVING PATH FOR PEDESTRIAN OR BICYCLES.
- RECYCLED WATER PIPELINES SHALL BE BURIED TO THE FOLLOWING DEPTH FROM FINISHED GRADE TO TOP OF PIPE:

- A: PRESSURIZED LINES 3" AND LARGER: 24 INCHES.
- B: PRESSURIZED LINES 2-1/2" AND SMALLER: 18 INCHES.
- C: INTERMITTENT PRESSURE LINES: 12 INCHES.

2

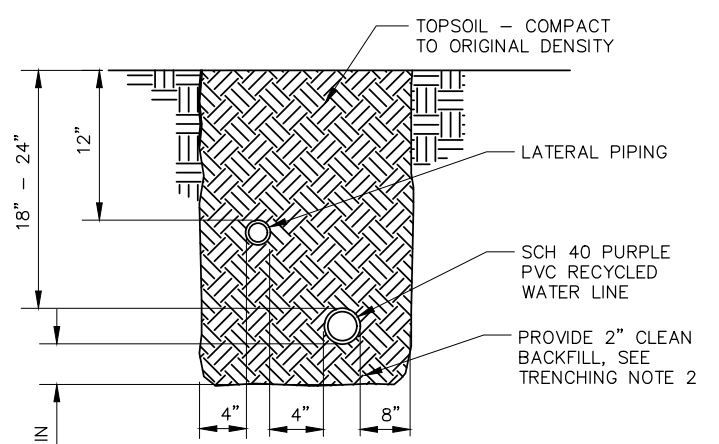

CONDITION 3: AT PLANTER AREA

1

TRENCHING DETAIL A
NOT TO SCALE

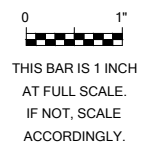

JOB NO. 419-001
DATE MAY 2017
DRAWN BY Drawn 1
DESIGNED BY Designer 1
PROJ. MGR. Proj. Mgr.

ZONE	REV	DESCRIPTION	DATE	APVD
REVISIONS				

**CITY OF HAYWARD
RECYCLED WATER
PROGRAM**

STANDARD DETAILS

**IRRIGATION TRENCHING
STANDARD DETAILS 3**

D3
DRAWING NUMBER
SHEET 3 OF 6

A B C D E F G H

SITUATION

CRITERIA

BASIC SEPARATION STANDARDS

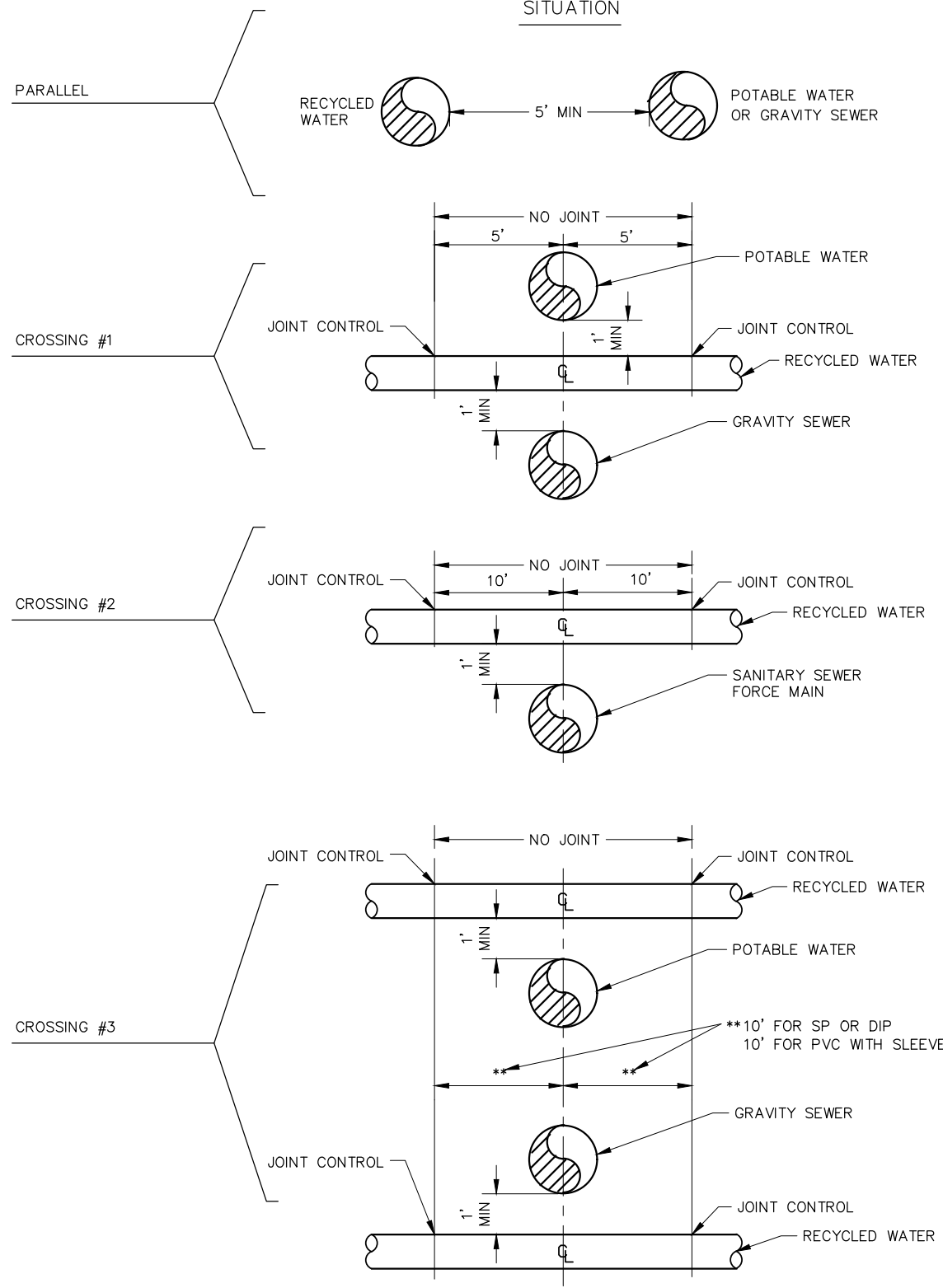

- * NO JOINT CONTROL FOR SP, DIP, AND PVC
- * JOINT CONTROL FOR SP, DIP, AND PVC
- * RECYCLED WATER PIPELINE SHOULD BE BELOW POTABLE WATER PIPELINES AND ABOVE STORM AND SANITARY SEWER PIPELINES.
- * NO PVC
- * SP WITH DOUBLE WELDED JOINTS
- * DIP WITH MECHANICAL RESTRAINT JOINTS
- * LOCATE JOINTS MIN. 10' FROM THE CROSSING

CASE 1. PARALLEL CONSTRUCTION
 WHEN THE RECYCLED WATER MAINS ARE AT LEAST 5 FEET (MEASURED FROM EDGE-OF-PIPE TO EDGE-OF-PIPE) FROM POTABLE WATER AND/OR SANITARY SEWER MAINS OR STORM DRAINS, THE RECYCLED WATER MAIN CAN BE INSTALLED WITH STEEL PIPE (SP), DUCTILE IRON PIPE (DIP), AND PLASTIC PIPE (PVC) WITHOUT JOINT CONTROL. WHEN LOCATED NEAR A SEWER FORCE MAIN, THE RECYCLED WATER MAIN IS TO BE CONSTRUCTED MAINTAINING THE 10 FEET MINIMUM SEPARATION REQUIREMENT AND ONLY SP AND DIP ARE ACCEPTABLE MATERIALS (SEE DETAIL).

CASE 2. CROSSING CONSTRUCTION
 2A. (SEE CROSSING #1 DETAIL) AT CROSSING WHERE THE RECYCLED WATER MAINS ARE TO BE CONSTRUCTED. MAINTAIN 1 FOOT MINIMUM VERTICAL CLEARANCE (MEASURED FROM EDGE-OF-PIPE TO EDGE-OF-PIPE) FROM ANY UNDERGROUND UTILITIES, INCLUDING POTABLE WATER LINES, SANITARY SEWERS, STORM DRAINS, GAS LINES, ELECTRICAL DUCTBANKS, ETC. WHEN THE RECYCLED WATER MAINS ARE 1 FOOT BELOW THE POTABLE WATER MAINS AND/OR 1 FOOT ABOVE THE SANITARY SEWER MAINS, THE PIPE JOINTS MUST BE LOCATED AT LEAST 5 FEET FROM THE EXISTING PIPE (MEASURED FROM CENTERLINE OF EXISTING PIPE TO THE JOINT). SP, DIP, AND PVC ARE ALL ACCEPTABLE PIPE MATERIALS.

2B. (SEE CROSSING #2 DETAIL) WHEN CROSSING A SANITARY SEWER FORCE MAIN, THE RECYCLED WATER MAIN MUST BE LOCATED AT LEAST 1 FOOT ABOVE THE EXISTING FORCE MAIN. ONLY SP WITH DOUBLE WELDED JOINTS AND DIP WITH MECHANICALLY RESTRAINED JOINTS ARE ACCEPTABLE. THE RECYCLED WATER PIPE JOINTS MUST BE LOCATED AT LEAST 10 FEET FROM THE CENTERLINE OF EXISTING SANITARY SEWERS FORCE MAIN.

2C. (SEE CROSSING #3 DETAIL) WHEN THE RECYCLED WATER MAINS ARE 1 FEET ABOVE THE POTABLE WATER LINES AND/OR 1 FOOT BELOW THE SANITARY SEWER MAINS, THE SP SHALL BE CONSTRUCTED WITH DOUBLE WELDED JOINTS, DIP USED SHALL HAVE MECHANICAL RESTRAINED JOINTS. BOTH SP AND DIP JOINTS MUST BE LOCATED AT LEAST 10 FEET FROM THE CENTERLINE OF EXISTING SANITARY SEWERS AND/OR EXISTING WATER LINES. IF THE PVC IS USED FOR RECYCLED WATER PIPELINE AT CROSSING, IN ADDITION TO THE JOINT THRUST RESTRAINT DEVICES, A CONTINUOUS SLEEVE FOR A DISTANCE OF 10 FEET ON EITHER SIDE OF CROSSING SHALL BE INSTALLED.

GENERAL NOTES

1. ALL SP USED FOR PIPING SHALL MEET A MINIMUM INTERNAL PRESSURE OF 200 PSI. NO MINIMUM PIPE WALL THICKNESS REQUIRED. (PIPE WALL THICKNESS SHALL BE CHOSEN BASED ON THE INTERNAL PRESSURES AND EXTERNAL LOADS EXERTED ON THE PIPE, THE MOST CONSERVATIVE DESIGN FOR PIPE WALL THICKNESS MUST BE SPECIFIED).
2. DIP USED FOR PIPING, THE STANDARD PIPE WALL THICKNESS SHALL BE DETERMINED BY THE STANDARD PIPELINE DESIGN, THERE IS NO MINIMUM INTERNAL PRESSURE REQUIREMENT.
3. PVC USED FOR PIPING, A DIMENSION RATIO (DR) OF 14 AND PRESSURE CLASS OF 200 MUST BE SPECIFIED. ALSO REFER TO AWWA C900 REQUIREMENTS.
4. PROPER CORROSION PROTECTION TO PIPELINES IS REQUIRED WHICH INCLUDES BUT IS NOT LIMITED TO OUTSIDE COATING, INSIDE LINING, DIELECTRIC TREATMENT, AND OTHER CATHODIC PROTECTION.
5. ANY EXCEPTIONS TO THE REQUIREMENTS OF THIS DETAIL REQUIRE A SPECIAL REVIEW AND APPROVAL SHALL BE GRANTED BY THE CALIFORNIA DIVISION OF DRINKING WATER.

CA DIVISION OF DRINKING WATER REVIEW AND WAIVER REQUIRED FOR CROSSING TYPE.

PIPE CLEARANCE REQUIREMENT DETAILS
 NOT TO SCALE



0 1"
 THIS BAR IS 1 INCH AT FULL SCALE. IF NOT, SCALE ACCORDINGLY.

JOB NO. 419-001
 DATE MAY 2017
 DRAWN BY Drawn 1
 DESIGNED BY Designer 1
 PROJ. MGR. Proj. Mgr.

ZONE	REV	DESCRIPTION	DATE	APVD

**CITY OF HAYWARD
 RECYCLED WATER
 PROGRAM**

STANDARD DETAILS

**IRRIGATION CLEARANCE
 REQUIREMENTS
 STANDARD DETAILS 4**

D4
 DRAWING NUMBER
 SHEET 4 OF 6

A B C D

**FOR FIRE SERVICES* AND WATER SERVICES
WHERE REQUIRED BY CCR, TITLE 17, § 7604**

*SEE SD-204 FOR ADDITIONAL REQUIREMENTS ON FIRE SERVICES 3" AND LARGER

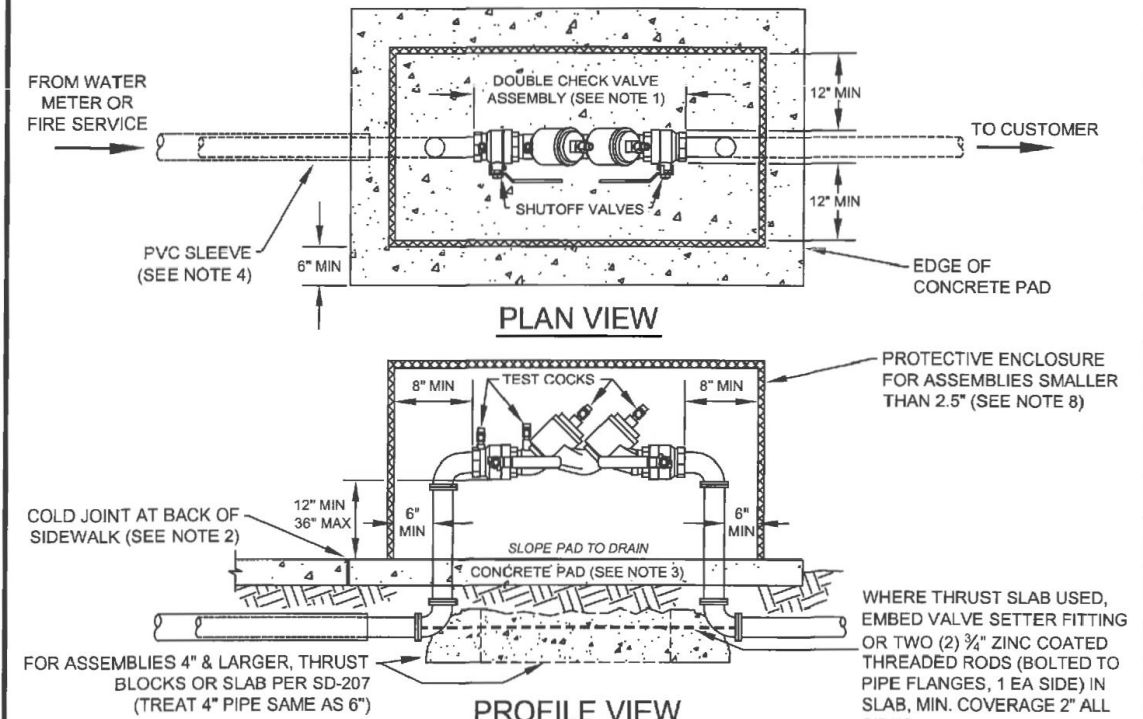

- NOTES:**
1. ALLOWED BACKFLOW ASSEMBLIES AND THEIR ORIENTATIONS SHALL BE LIMITED TO THOSE SPECIFIED ON THE "LIST OF APPROVED BACKFLOW PREVENTION ASSEMBLIES," BY THE UNIVERSITY OF SOUTHERN CALIFORNIA'S FOUNDATION FOR CROSS-CONNECTION CONTROL AND HYDRAULIC RESEARCH, 2010 OR LATEST REVISION.
 2. THE BACKFLOW DEVICE SHALL BE LOCATED: (A) A MAXIMUM OF 5' FROM BACK OF SIDEWALK (TYP.); (B) WHERE SCREENING IS REQUIRED, A MAXIMUM OF 30' FROM BACK OF SIDEWALK; OR (C) AT A LOCATION DETERMINED BY THE WATER DISTRIBUTION CROSS CONNECTION PERSONNEL IN THE FIELD.
 3. CONCRETE PAD SHALL BE CLASS B CONCRETE, 4" MINIMUM THICKNESS, REINFORCED WITH WELDED WIRE MESH.
 4. WHERE SERVICE LINES SMALLER THAN 4" PASS UNDER A SIDEWALK, THEY SHALL BE INSTALLED IN A PVC CASING/SLEEVE AT LEAST 1" LARGER THAN THE SERVICE LINE AND EXTENDS AT LEAST 6" BEYOND THE EDGES OF THE SIDEWALK.
 5. METAL PIPES EXPOSED TO SOIL OR CONCRETE SHALL BE COATED WITH 3M SCOTCHWRAP PIPE PRIMER AND WRAPPED WITH 3M SCOTCHWRAP NO. 51 BLACK PVC TAPE (¾" OVERLAP).
 6. THE PORTION OF THE TRENCH FROM BACK OF METER TO THE DEVICE SHALL REMAIN OPEN UNTIL WATER DISTRIBUTION CROSS CONNECTION PERSONNEL HAVE INSPECTED AND APPROVED THE INSTALLATION.
 7. THE TESTING SIDE OF THE DEVICE SHALL HAVE A MINIMUM 24" OF CLEARANCE FROM OBSTRUCTIONS (NON-TRIMABLE LANDSCAPING, BUILDINGS, UTILITIES, ETC.). MULTIPLE BACKFLOW DEVICES SHALL BE SEPARATED BY A MINIMUM OF 18".
 8. BACKFLOW ASSEMBLIES SMALLER THAN 2.5" SHALL BE COVERED WITH AN INSULATION BLANKET, MIN R-13, GREEN, WEATHERGUARD OR EQUAL AND PROTECTED BY A LOCKABLE WIRE CAGE ENCLOSURE FASTENED TO THE PAD. THE ENCLOSURE SHALL BE HINGED, POWDER COATED GREEN AND SECURED WITH A DOUBLE-LOCKED GALVANIZED CHAIN SUCH THAT EITHER LOCK CAN RELEASE THE CHAIN. ONE LOCK WILL BE SUPPLIED BY CITY.
 9. BACKFLOW ASSEMBLIES 2.5" AND LARGER SHALL BE SECURED BY A DOUBLE-LOCKED, GALVANIZED, STRAIGHT LINK CHAIN THAT LOCKS THE VALVE HANDWHEELS IN THE OPEN POSITION AND EITHER LOCK CAN RELEASE THE CHAIN. ONE LOCK WILL BE SUPPLIED BY CITY. IN AREAS PRONE TO VANDALISM, CITY MAY ADDITIONALLY REQUIRE A LOCKABLE PROTECTIVE ENCLOSURE (SEE NOTE 8).
 10. BOLLARDS MAY BE REQUIRED BY CITY TO PROVIDE ADDITIONAL PROTECTION (SEE SD-223 FOR BOLLARD DETAIL).
 11. BACKFLOW ASSEMBLIES INSTALLED ON POTABLE WATER SERVICES SHALL BE LEAD FREE.
 12. BACKFLOW ASSEMBLIES SHALL BE AT LEAST THE SIZE OF THE WATER METER OR THE WATER SUPPLY LINE ON THE PROPERTY SIZE OF THE METER, WHICHEVER IS LARGER.

CITY OF HAYWARD PUBLIC WORKS DEPT.		STANDARD DOUBLE CHECK VALVE ASSEMBLIES	DWG. NO. SD-201
DRW BY: RS	DATE: 11/30/12		FILED
CHKD BY: AA	SCALE: NTS		
APPD. BY: [Signature]	APPROVED: [Signature]		SHT. 1 OF 1
REV	DATE	BY	CITY ENGINEER

FIRE WATER BACKFLOW ASSEMBLY DETAIL (A)
NOT TO SCALE

E F G H

**FOR IRRIGATION AND WATER SERVICES
WHERE REQUIRED BY CCR, TITLE 17, § 7604**

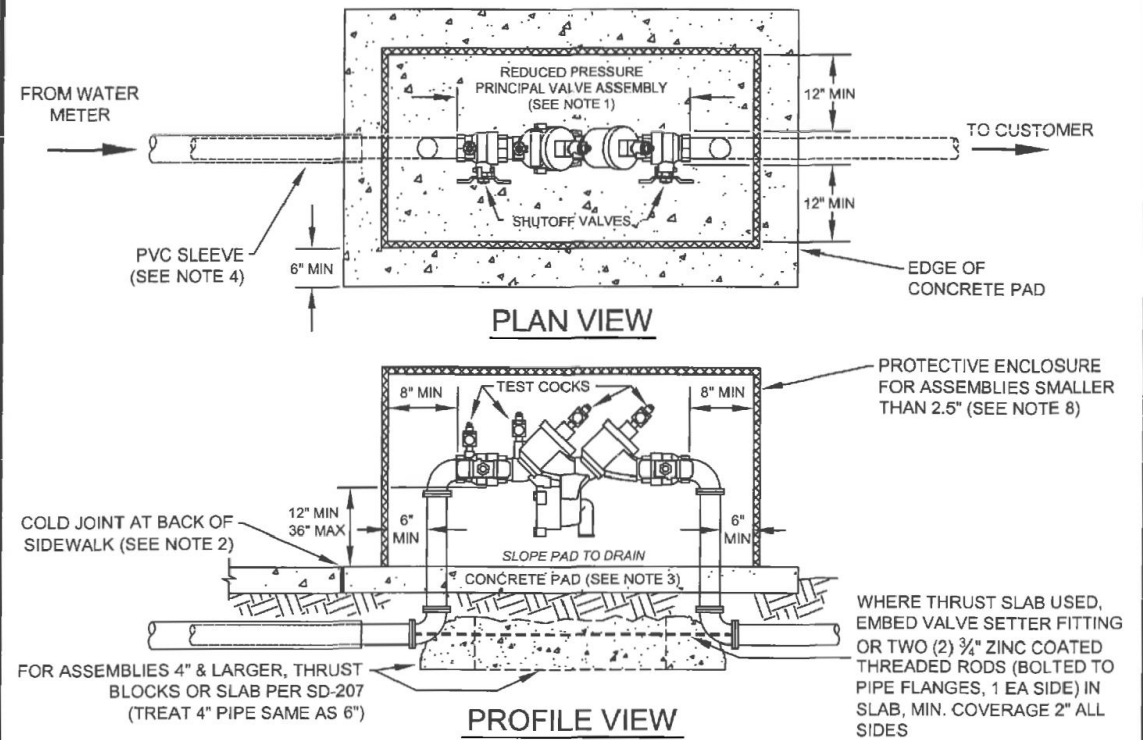

- NOTES:**
1. ALLOWED BACKFLOW ASSEMBLIES AND THEIR ORIENTATIONS SHALL BE LIMITED TO THOSE SPECIFIED ON THE "LIST OF APPROVED BACKFLOW PREVENTION ASSEMBLIES," BY THE UNIVERSITY OF SOUTHERN CALIFORNIA'S FOUNDATION FOR CROSS-CONNECTION CONTROL AND HYDRAULIC RESEARCH, 2010 OR LATEST REVISION.
 2. THE BACKFLOW DEVICE SHALL BE LOCATED: (A) A MAXIMUM OF 5' FROM BACK OF SIDEWALK (TYP.); (B) WHERE SCREENING IS REQUIRED, A MAXIMUM OF 30' FROM BACK OF SIDEWALK; OR (C) AT A LOCATION DETERMINED BY THE WATER DISTRIBUTION CROSS CONNECTION PERSONNEL IN THE FIELD.
 3. CONCRETE PAD SHALL BE CLASS B CONCRETE, 4" MINIMUM THICKNESS, REINFORCED WITH WELDED WIRE MESH.
 4. WHERE SERVICE LINES SMALLER THAN 4" PASS UNDER A SIDEWALK, THEY SHALL BE INSTALLED IN A PVC CASING/SLEEVE AT LEAST 1" LARGER THAN THE SERVICE LINE AND EXTENDS AT LEAST 6" BEYOND THE EDGES OF THE SIDEWALK.
 5. METAL PIPES EXPOSED TO SOIL OR CONCRETE SHALL BE COATED WITH 3M SCOTCHWRAP PIPE PRIMER AND WRAPPED WITH 3M SCOTCHWRAP NO. 51 BLACK PVC TAPE (¾" OVERLAP).
 6. THE PORTION OF THE TRENCH FROM BACK OF METER TO THE DEVICE SHALL REMAIN OPEN UNTIL WATER DISTRIBUTION CROSS CONNECTION PERSONNEL HAVE INSPECTED AND APPROVED THE INSTALLATION.
 7. THE TESTING SIDE OF THE DEVICE SHALL HAVE A MINIMUM 24" OF CLEARANCE FROM OBSTRUCTIONS (NON-TRIMABLE LANDSCAPING, BUILDINGS, UTILITIES, ETC.). MULTIPLE BACKFLOW DEVICES SHALL BE SEPARATED BY A MINIMUM OF 18".
 8. BACKFLOW ASSEMBLIES SMALLER THAN 2.5" SHALL BE COVERED WITH AN INSULATION BLANKET, MIN R-13, GREEN, WEATHERGUARD OR EQUAL AND PROTECTED BY A LOCKABLE WIRE CAGE ENCLOSURE FASTENED TO THE PAD. THE ENCLOSURE SHALL BE HINGED, POWDER COATED GREEN AND SECURED WITH A DOUBLE-LOCKED GALVANIZED CHAIN SUCH THAT EITHER LOCK CAN RELEASE THE CHAIN. ONE LOCK WILL BE SUPPLIED BY CITY.
 9. BACKFLOW ASSEMBLIES 2.5" AND LARGER SHALL BE SECURED BY A DOUBLE-LOCKED, GALVANIZED, STRAIGHT LINK CHAIN THAT LOCKS THE VALVE HANDWHEELS IN THE OPEN POSITION AND EITHER LOCK CAN RELEASE THE CHAIN. ONE LOCK WILL BE SUPPLIED BY CITY. IN AREAS PRONE TO VANDALISM, CITY MAY ADDITIONALLY REQUIRE A LOCKABLE PROTECTIVE ENCLOSURE (SEE NOTE 8).
 10. BOLLARDS MAY BE REQUIRED BY CITY TO PROVIDE ADDITIONAL PROTECTION (SEE SD-223 FOR BOLLARD DETAIL).
 11. BACKFLOW ASSEMBLIES INSTALLED ON POTABLE WATER SERVICES SHALL BE LEAD FREE.
 12. BACKFLOW ASSEMBLIES SHALL BE AT LEAST THE SIZE OF THE WATER METER OR THE WATER SUPPLY LINE ON THE PROPERTY SIZE OF THE METER, WHICHEVER IS LARGER.

CITY OF HAYWARD PUBLIC WORKS DEPT.		STANDARD - REDUCED PRESSURE PRINCIPAL BACKFLOW PREVEN- TION ASSEMBLIES	DWG. NO. SD-202
DRW BY: RS	DATE: 11/30/12		FILED
CHKD BY: AA	SCALE: NTS		
APPD. BY: [Signature]	APPROVED: [Signature]		SHT. 1 OF 1
REV	DATE	BY	CITY ENGINEER

IRRIGATION BACKFLOW ASSEMBLY DETAIL (B)
NOT TO SCALE

	<p>THIS BAR IS 1 INCH AT FULL SCALE. IF NOT, SCALE ACCORDINGLY.</p>	JOB NO. 419-001 DATE MAY 2017 DRAWN BY Drawn.1 DESIGNED BY Designer.1 PROJ. MGR. Proj. Mgr.	ZONE REV DESCRIPTION DATE APVD REVISIONS	CITY OF HAYWARD RECYCLED WATER PROGRAM	STANDARD DETAILS	IRRIGATION BACKFLOW PREVENTER ASSEMBLY STANDARD DETAILS 5	D5 DRAWING NUMBER SHEET 5 OF 6
		A	B	C	D	E	F

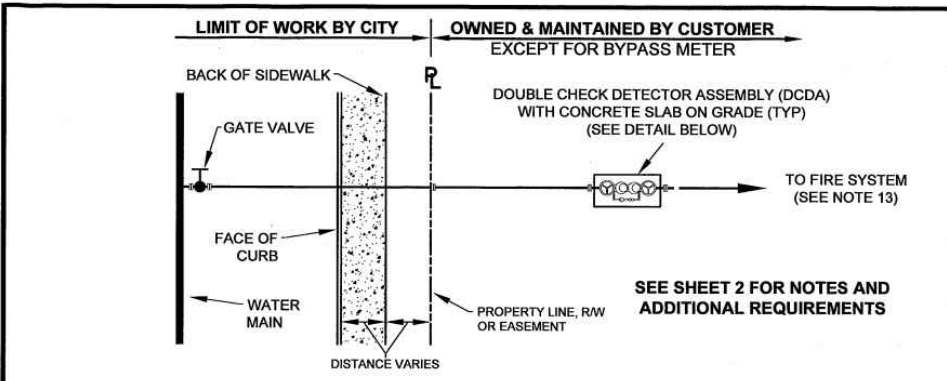

CITY RESPONSIBILITY ENDS AT THE PROPERTY LINE (R), RIGHT-OF-WAY (R/W) OR EASEMENT, AS APPLICABLE TO THE LOCATION OF THE FIRE SERVICE, WITH THE EXCEPTION OF ANNUAL TESTING. CUSTOMER OWNS AND SHALL MAINTAIN ALL THE COMPONENTS OF THE FIRE SYSTEM WITHIN THE PROPERTY LINES (INCLUDING BUT NOT LIMITED TO, DCDA, PIV, FDC, CAGE, BOLLARDS, CHAINS, LOCKS, ETC.), WITH THE EXCEPTION OF THE CITY'S BYPASS METER.

FIRE SERVICE SCHEMATIC

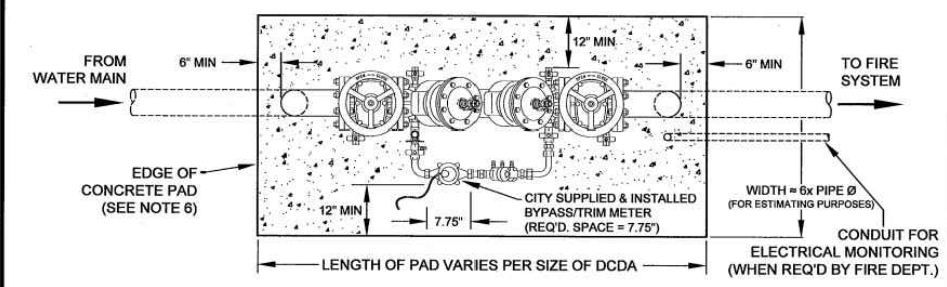

SEE SD-201 FOR ADDITIONAL REQUIREMENTS

DCDA DETAIL, PLAN VIEW

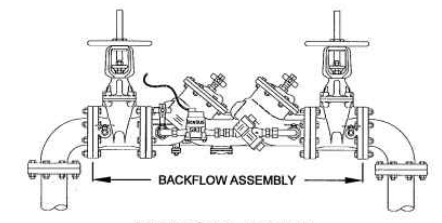

TYPICAL DCDA PROFILE VIEW

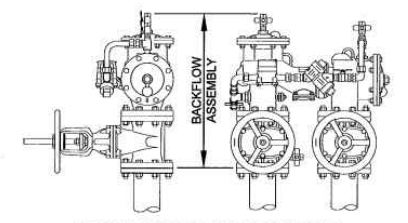

CONFIGURABLE DCDA PROFILE VIEWS

		STANDARD FIRE SERVICE 3" AND LARGER	DWG. NO. SD-204
DRW BY: RS	DATE: 8/10/2011		FILED
CHKD BY: [Signature]	SCALE: NTS	SHT. 1 OF 2	
BY: [Signature]	DIR. PUBLIC WORKS		

- NOTES:**
- BACKFLOW ASSEMBLIES SHALL BE FACTORY ASSEMBLED, WITH THE EXCEPTION OF THE BYPASS METER. ALLOWED DCDA's AND THEIR ORIENTATIONS SHALL BE LIMITED TO THOSE SPECIFIED ON THE "LIST OF APPROVED BACKFLOW PREVENTION ASSEMBLIES," BY THE UNIVERSITY OF SOUTHERN CALIFORNIA'S FOUNDATION FOR CROSS-CONNECTION CONTROL AND HYDRAULIC RESEARCH, 2010 OR LATEST REVISION.
 - FIRE SERVICES MAY BE INSTALLED BY A CONTRACTOR AS PART OF A WATER MAIN THAT THE CONTRACTOR IS CONSTRUCTING AFTER CITY HAS APPROVED PLANS DETAILING THE PROPOSED WATER MAIN AND FIRE SERVICES.
 - ALL PLANS DETAILING FIRE SERVICES SHALL BE APPROVED BY CITY PRIOR TO INSTALLATION.
 - ALL FIRE SERVICES TO BE CONNECTED TO EXISTING LIVE WATER MAINS AND ALL BYPASS/TRIM METERS SHALL BE INSTALLED BY WATER DIVISION PERSONNEL ONLY.
 - THE BACKFLOW DEVICE SHALL BE LOCATED: (A) A MAXIMUM OF 5' FROM BACK OF SIDEWALK (TYP); (B) WHERE SCREENING IS REQUIRED, A MAXIMUM OF 30" FROM BACK OF SIDEWALK; OR (C) AT A LOCATION DETERMINED BY THE WATER DISTRIBUTION CROSS CONNECTION PERSONNEL IN THE FIELD.
 - CONCRETE PAD SHALL BE CLASS B CONCRETE, 4" MINIMUM THICKNESS, REINFORCED WITH WELDED WIRE MESH.
 - THE PORTION OF THE TRENCH FROM BACK OF SIDEWALK TO THE DEVICE SHALL REMAIN OPEN UNTIL WATER DISTRIBUTION CROSS CONNECTION PERSONNEL HAVE INSPECTED AND APPROVED THE INSTALLATION.
 - THE TESTING SIDE OF THE DEVICE SHALL HAVE A MINIMUM 24" OF CLEARANCE FROM OBSTRUCTIONS (NON-TRIMMABLE LANDSCAPING, BUILDINGS, UTILITIES, ETC.). MULTIPLE BACKFLOW DEVICES SHALL BE SEPARATED BY A MINIMUM OF 18".
 - DCDA's SHALL BE SECURED BY A DOUBLE-LOCKED, GALVANIZED, STRAIGHT LINK CHAIN THAT LOCKS THE VALVE HAND-WHEELS OPEN, SUCH THAT EITHER LOCK CAN RELEASE THE CHAIN. ONE LOCK WILL BE SUPPLIED BY CITY. IN AREAS PRONE TO VANDALISM, A LOCKABLE PROTECTIVE ENCLOSURE MAY ALSO BE REQUIRED BY CITY (SEE SD-201).
 - THE BYPASS ASSEMBLY, INCLUDING THE METER, SHALL BE COVERED WITH AN INSULATION BLANKET, MIN R-13.
 - BOLLARDS MAY BE REQUIRED BY CITY FOR ADDITIONAL PROTECTION (SEE SD-223 FOR BOLLARD DETAIL).
 - TOUCHREAD SENSOR OF BYPASS METER SHALL BE MOUNTED TO AND THROUGH THE SIDE OF THE PROTECTIVE ENCLOSURE OR, IF NO ENCLOSURE, ATTACHED TO THE DCDA, AS DETERMINED BY THE WATER DISTRIBUTION PERSONNEL IN THE FIELD. TOUCHREAD SENSOR WIRE SHALL BE NEATLY SECURED TO THE DCDA.
 - POST INDICATOR VALVE (PIV) AND FIRE DEPARTMENT CONNECTION (FDC) SHALL BE CONNECTED TO THE FIRE SYSTEM DOWNSTREAM OF THE DCDA, PER THE FIRE DEPARTMENT'S REQUIREMENTS.
 - BELOW GRADE OR INTERIOR INSTALLATIONS OF BACKFLOW DEVICES WILL ONLY BE CONSIDERED ON A CASE-BY-CASE BASIS AND WHEN SPACE LIMITATIONS PREVENT USE OF AN ABOVE GRADE DEVICE. SUCH INSTALLATIONS MAY REQUIRE THE ADDITION OF A BURIED DETECTOR CHECK VALVE ASSEMBLY INSTALLED BY CITY WATER DISTRIBUTION PERSONNEL.

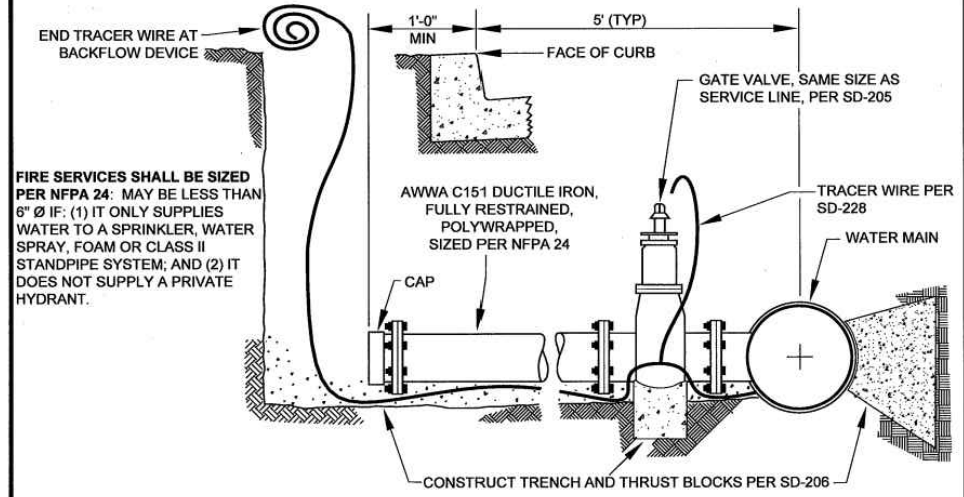

FIRE SERVICES SHALL BE SIZED PER NFPA 24: MAY BE LESS THAN 6" Ø IF: (1) IT ONLY SUPPLIES WATER TO A SPRINKLER, WATER SPRAY, FOAM OR CLASS II STANDPIPE SYSTEM; AND (2) IT DOES NOT SUPPLY A PRIVATE HYDRANT.

FIRE SERVICE CONSTRUCTION DETAIL

		STANDARD FIRE SERVICE 3" AND LARGER	DWG. NO. SD-204
DRW BY: RS	DATE: 8/10/2011		FILED
CHKD BY: [Signature]	SCALE: NTS	SHT. 2 OF 2	
BY: [Signature]	DIR. PUBLIC WORKS		

NOTES:

- FIRE SERVICE DCDA BACKFLOW PREVENTION DETAILS TO BE INCLUDED ON FORMAL SUBMITTAL TO FIRE MARSHAL FOR CONSTRUCTION PERMITTING.

TYPICAL FIRE SERVICE BACKFLOW ASSEMBLY DETAIL

NOT TO SCALE

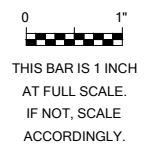

JOB NO. 419-001
DATE MAY 2017
DRAWN BY Drawn.1
DESIGNED BY Designer.1
PROJ. MGR. Proj. Mgr.

ZONE	REV	DESCRIPTION	DATE	APVD

**CITY OF HAYWARD
RECYCLED WATER
PROGRAM**

STANDARD DETAILS

**FIRE SERVICE BACKFLOW
ASSEMBLY
STANDARD DETAIL 6**

D6
DRAWING NUMBER
SHEET 6 OF 6

Appendix F – Quarterly Self-Monitoring Monitoring Report



**CITY OF HAYWARD RECYCLED WATER PROGRAM
QUARTERLY CUSTOMER SELF-MONITORING REPORT**

Name/Location of Site:	Customer's designated Recycled Water Site Supervisor:
------------------------	---

MONITORING DATA				
	Q1	Q2	Q3	Q4
Is recycled water escaping the use area through surface run off, airborne spray, or overflow of impoundments such as fountains? (If yes, note affected area the estimate volume in area provided below. Is recycled water escaping the use area through surface run off, airborne spray, or overflow of impoundments such as fountains? (If yes, note affected area the estimate volume in area provided below.)	Yes No	Yes No	Yes No	Yes No
Any observations of odor of wastewater origin on the site irrigated with RW? (Note source, characterizations, and direction of travel below.)	Yes No	Yes No	Yes No	Yes No
Is there prolonged ponding of recycled water or evidence of mosquitoes breeding within the irrigation area as a result of ponding water?	Yes No	Yes No	Yes No	Yes No
Are all warning signs, labels, and markings identifying recycled water in place, legible, and visible?	Yes No	Yes No	Yes No	Yes No
Are there leaks or breaks in the irrigation system piping or evidence of plugged, broken, or otherwise faulty irrigation system components?	Yes No	Yes No	Yes No	Yes No
Is recycled water being sprayed directly on people, dwellings, food handling facilities, or drinking fountains?	Yes No	Yes No	Yes No	Yes No
Explain any "yes" answers. Note date of comment and specific locations within the site. Attach additional sheets if necessary.				

NOTES	
Note any recommended improvements or changes:	
List any changes in recycled water piping system from previous monitoring report. Explain:	
_____ Recycled Water Site Supervisor (Date)	Reports must be submitted by March 15, June 15, September 15, and December 15 of each year to the City of Hayward as specified in the Customer's Recycled Water Use Permit.

Appendix G – Coverage Test Form

COVERAGE TEST FORM

Recycled Water Account Number(s): _____

Date: _____

Site Name: _____

Service Address: _____

Inspected by: _____

1. Is there evidence of recycled water runoff from the site? Yes No

If yes, show affected area on a sketch and estimate volume. _____

2. Is there an odor of wastewater origin at the irrigation site? Yes No If yes, indicate:

Apparent source _____ Direction of Travel _____

Characterization _____

3. Is there evidence of ponding of recycled water? Yes No

Evidence of mosquitoes breeding within irrigation area due to ponding water? Yes No

4. Are the following posted to inform the public that the irrigation water is recycled water, and is not suitable for drinking? Warning signs Tags Stickers Above ground pipe markings

5. Is there evidence of leaks or breaks in the irrigation system piping or tubing? Yes No

6. Is there evidence of broken or otherwise faulty drip irrigation system emitters or spray irrigation sprinklers? Yes No

7. What corrective actions were taken to correct any problems noted above and when were they corrected?

Signature _____ Date _____

Site Supervisor

Appendix H – Recycled Water Do's and Don'ts

Do's

- ☑ *Practice Good Maintenance. Promptly repair any leaks or breaks on your on-site irrigation system and use only materials approved for recycled water use.*
- ☑ *Report Recycled Water Leaks. Report any line breaks or recycled water leaving your site.*
- ☑ *Monitor the Performance of your Irrigation System. Avoid over-irrigating and over-saturating your soils and avoid irrigating during rain events.*
- ☑ *Know Your Potable and Recycled Water Distribution Systems. Keep up-to-date as-built drawings of both systems and be familiar with each system.*
- ☑ *Minimize Public Contact with Recycled Water. Operate your recycled water irrigation system during low public use. The City recommends irrigating between 9 pm and 6 am for most customers.*
- ☑ *Practice Good Hygiene. Wash hands and promptly disinfect and bandage abrasions and cuts, as you would when working in any landscape work environment.*
- ☑ *Maintain Recycled Water Signage at Your Site. Maintain all signs, tags, or stickers that inform your staff and the general public that recycled water is being used on your site.*
- ☑ *Be Informed About Using Recycled Water. Become familiar with the City's Recycled Water Use Guidelines and train appropriate staff on the proper use of recycled water.*

Don'ts

- ☒ *Drink Recycled Water. Recycled water is suitable for landscape irrigation and other approved non-potable uses, but not for drinking.*
- ☒ *Create Over-Spray, Run-off Conditions, or Ponding. Keep recycled water contained within your site and only apply the appropriate amount to achieve adequate watering.*
- ☒ *Create Cross-Connections. When making new connections to your on-site water systems, be sure not to cross-connect your recycled water system with any other water system on your site.*
- ☒ *Use Hose Bibs on your Recycled Water System. Use only quick couplers that differ from those used on the potable water system.*